

---

---

**Mechanical properties of fasteners made  
of carbon steel and alloy steel —**

Part 2:

**Nuts with specified property classes —  
Coarse thread and fine pitch thread**

*Caractéristiques mécaniques des éléments de fixation en acier au  
carbone et en acier allié —*

*Partie 2: Écrous de classes de qualité spécifiées — Filetages à pas  
gros et filetages à pas fin*





**COPYRIGHT PROTECTED DOCUMENT**

© ISO 2012

All rights reserved. Unless otherwise specified, no part of this publication may be reproduced or utilized in any form or by any means, electronic or mechanical, including photocopying and microfilm, without permission in writing from either ISO at the address below or ISO's member body in the country of the requester.

ISO copyright office  
Case postale 56 • CH-1211 Geneva 20  
Tel. + 41 22 749 01 11  
Fax + 41 22 749 09 47  
E-mail [copyright@iso.org](mailto:copyright@iso.org)  
Web [www.iso.org](http://www.iso.org)

Published in Switzerland

# Contents

Page

Foreword .....	iv
<b>1 Scope .....</b>	<b>1</b>
<b>2 Normative references .....</b>	<b>2</b>
<b>3 Symbols .....</b>	<b>2</b>
<b>4 Designation systems .....</b>	<b>2</b>
<b>4.1 Designation of nut styles .....</b>	<b>2</b>
<b>4.2 Designation of property classes .....</b>	<b>2</b>
<b>4.3 Ranges of nominal diameters in relation to nut style and property class .....</b>	<b>3</b>
<b>5 Design of bolt and nut assemblies .....</b>	<b>3</b>
<b>6 Materials .....</b>	<b>4</b>
<b>7 Mechanical properties .....</b>	<b>5</b>
<b>8 Inspection .....</b>	<b>8</b>
<b>8.1 Manufacturer's inspection .....</b>	<b>8</b>
<b>8.2 Supplier's inspection .....</b>	<b>8</b>
<b>8.3 Purchaser's inspection .....</b>	<b>8</b>
<b>9 Test methods .....</b>	<b>9</b>
<b>9.1 Proof load test .....</b>	<b>9</b>
<b>9.2 Hardness test .....</b>	<b>11</b>
<b>9.3 Surface integrity inspection .....</b>	<b>13</b>
<b>10 Marking .....</b>	<b>13</b>
<b>10.1 General .....</b>	<b>13</b>
<b>10.2 Identification mark of the manufacturer .....</b>	<b>13</b>
<b>10.3 Marking of property classes .....</b>	<b>13</b>
<b>10.4 Identification .....</b>	<b>14</b>
<b>10.5 Marking of left-hand thread .....</b>	<b>15</b>
<b>10.6 Marking of packages .....</b>	<b>15</b>
<b>Annex A (informative) Design principles of nuts .....</b>	<b>16</b>
<b>Annex B (informative) Thread dimensions for the test mandrel .....</b>	<b>19</b>
<b>Bibliography .....</b>	<b>21</b>

## Foreword

ISO (the International Organization for Standardization) is a worldwide federation of national standards bodies (ISO member bodies). The work of preparing International Standards is normally carried out through ISO technical committees. Each member body interested in a subject for which a technical committee has been established has the right to be represented on that committee. International organizations, governmental and non-governmental, in liaison with ISO, also take part in the work. ISO collaborates closely with the International Electrotechnical Commission (IEC) on all matters of electrotechnical standardization.

International Standards are drafted in accordance with the rules given in the ISO/IEC Directives, Part 2.

The main task of technical committees is to prepare International Standards. Draft International Standards adopted by the technical committees are circulated to the member bodies for voting. Publication as an International Standard requires approval by at least 75 % of the member bodies casting a vote.

Attention is drawn to the possibility that some of the elements of this document may be the subject of patent rights. ISO shall not be held responsible for identifying any or all such patent rights.

ISO 898-2 was prepared by Technical Committee ISO/TC 2, *Fasteners*, Subcommittee SC 12, *Fasteners with metric internal thread*.

This third edition cancels and replaces the second edition (ISO 898-2:1992) and ISO 898-6:1994, which have been technically revised.

ISO 898 consists of the following parts, under the general title *Mechanical properties of fasteners made of carbon steel and alloy steel*:

- *Part 1: Bolts, screws and studs with specified property classes — Coarse thread and fine pitch thread*
- *Part 2: Nuts with specified property classes — Coarse thread and fine pitch thread*
- *Part 5: Set screws and similar threaded fasteners with specified hardness classes — Coarse thread and fine pitch thread*
- *Part 7: Torsional test and minimum torques for bolts and screws with nominal diameters 1 mm to 10 mm<sup>1)</sup>*

---

1) It is intended that, upon revision, the main element of the title of Part 7 will be aligned with the main element of the title of Part 1.

# Mechanical properties of fasteners made of carbon steel and alloy steel —

## Part 2: Nuts with specified property classes — Coarse thread and fine pitch thread

### 1 Scope

This part of ISO 898 specifies mechanical and physical properties of nuts with coarse thread and fine pitch thread made of carbon steel and alloy steel when tested at an ambient temperature range of 10 °C to 35 °C.

Nuts conforming to the requirements of this part of ISO 898 are evaluated at that ambient temperature range. It is possible that they do not retain the specified mechanical and physical properties at elevated and/or lower temperatures.

NOTE 1 Nuts conforming to the requirements of this part of ISO 898 have been used in applications ranging from –50 °C to +150 °C. It is the responsibility of users to consult an experienced fastener materials expert for temperatures outside the range of –50 °C to +150 °C and up to a maximum temperature of +300 °C to determine appropriate choices for a given application.

NOTE 2 Information for the selection and application of steels for use at lower and elevated temperatures is given for instance in EN 10269, ASTM F2281 and in ASTM A320/A320M.

This part of ISO 898 is applicable to nuts:

- a) made of carbon steel or alloy steel;
- b) with coarse thread  $M5 \leq D \leq M39$ , and fine pitch thread  $M8 \times 1 \leq D \leq M39 \times 3$ ;
- c) with triangular ISO metric thread according to ISO 68-1;
- d) with diameter/pitch combinations according to ISO 261 and ISO 262;
- e) with specified property classes, including proof load;
- f) with different nut styles: thin nuts, regular nuts and high nuts;
- g) with minimum height  $m \geq 0,45D$ ;
- h) with a minimum outside diameter or width across flats  $s \geq 1,45D$  (see Annex A);
- i) able to mate with bolts, screws and studs with property classes according to ISO 898-1.

For hot dip galvanized nuts, see ISO 10684.

This part of ISO 898 does not specify requirements for properties such as:

- prevailing torque properties (see ISO 2320);
- torque/clamp force properties (see ISO 16047 for test method);
- weldability;
- corrosion resistance.

## 2 Normative references

The following referenced documents are indispensable for the application of this document. For dated references, only the edition cited applies. For undated references, the latest edition of the referenced document (including any amendments) applies.

ISO 6157-2, *Fasteners — Surface discontinuities — Part 2: Nuts*

ISO 6506-1, *Metallic materials — Brinell hardness test — Part 1: Test method*

ISO 6507-1, *Metallic materials — Vickers hardness test — Part 1: Test method*

ISO 6508-1, *Metallic materials — Rockwell hardness test — Part 1: Test method (scales A, B, C, D, E, F, G, H, K, N, T)*

ISO 6892-1, *Metallic materials — Tensile testing — Part 1: Method of test at room temperature*

ISO 7500-1, *Metallic materials — Verification of static uniaxial testing machines — Part 1: Tension/compression testing machines — Verification and calibration of the force-measuring system*

ISO 16426, *Fasteners — Quality assurance system*

## 3 Symbols

For the purposes of this document, the following symbols apply.

$D$	nominal thread diameter of the nut, in millimetres
$d_h$	hole diameter of the grip, in millimetres
$F$	load, in newtons
$h$	thickness of the grip, in millimetres
$m$	height of the nut, in millimetres
$P$	pitch of the thread, in millimetres
$s$	width across flats, in millimetres

## 4 Designation systems

### 4.1 Designation of nut styles

This part of ISO 898 specifies requirements for three styles of nuts according to their height:

- style 2: high nut with minimum height  $m_{\min} \approx 0,9D$  or  $m_{\min} > 0,9D$ ; see Table A.1;
- style 1: regular nut with minimum height  $m_{\min} \geq 0,8D$ ; see Table A.1;
- style 0: thin nut with minimum height  $0,45D \leq m_{\min} < 0,8D$ .

### 4.2 Designation of property classes

#### 4.2.1 General

The marking and labelling of nuts with property classes shall be as specified in Clause 10 for only those nuts which meet all applicable requirements of this part of ISO 898.

#### 4.2.2 Regular nuts (style 1) and high nuts (style 2)

The symbol for property classes of regular nuts (style 1) and high nuts (style 2) consists of one number. It corresponds to the number to the left of the appropriate maximum property class of bolts, screws and studs with which they can be mated.

#### 4.2.3 Thin nuts (style 0)

The symbol for property classes of thin nuts (style 0) consists of two numbers, specified in the following ways:

- the first number is zero, indicating that the loadability of the nut is reduced in comparison with the loadability of a regular nut or a high nut according to 4.2.2 and therefore thread stripping can occur when overloaded;
- the second number corresponds to 1/100 of the nominal stress under proof load on a hardened test mandrel, in megapascals.

### 4.3 Ranges of nominal diameters in relation to nut style and property class

The ranges of nominal diameters in relation to nut style and property class are as given in Table 1.

**Table 1 — Ranges of nominal diameters in relation to nut style and property class**

Property class	Range of nominal diameters, $D$		
	Regular nut (style 1)	High nut (style 2)	Thin nut (style 0)
04	—	—	$M5 \leq D \leq M39$ $M8 \times 1 \leq D \leq M39 \times 3$
05	—	—	$M5 \leq D \leq M39$ $M8 \times 1 \leq D \leq M39 \times 3$
5	$M5 \leq D \leq M39$ $M8 \times 1 \leq D \leq M39 \times 3$	—	—
6	$M5 \leq D \leq M39$ $M8 \times 1 \leq D \leq M39 \times 3$	—	—
8	$M5 \leq D \leq M39$ $M8 \times 1 \leq D \leq M39 \times 3$	$M5 < D \leq M39$ $M8 \times 1 \leq D \leq M39 \times 3$	—
9	—	$M5 \leq D \leq M39$	—
10	$M5 \leq D \leq M39$ $M8 \times 1 \leq D \leq M16 \times 1,5$	$M5 \leq D \leq M39$ $M8 \times 1 \leq D \leq M39 \times 3$	—
12	$M5 \leq D \leq M16$	$M5 \leq D \leq M39$ $M8 \times 1 \leq D \leq M16 \times 1,5$	—

## 5 Design of bolt and nut assemblies

Explanations of basic design principles of nuts and loadability of bolted assemblies are given in Annex A.

Regular nuts (style 1) and high nuts (style 2) shall be mated with externally threaded fasteners according to Table 2. However, nuts of a higher property class may replace nuts of a lower property class.

**Table 2 — Combination of regular nuts (style 1) and high nuts (style 2) with bolt property classes**

Nut property class	Maximum property class of mating bolt, screw and stud
5	5.8
6	6.8
8	8.8
9	9.8
10	10.9
12	12.9/ <u>12.9</u>

A decrease of thread stripping strength occurs for nuts with a fundamental deviation greater than zero for tolerance class 6H (such as hot dip galvanized nuts: 6AZ, 6AX). Thin nuts (style 0) have a reduced loadability compared to regular nuts or high nuts, and are not designed to provide resistance to thread stripping.

Thin nuts used as jam nuts should be assembled together with a regular nut or a high nut. In assemblies with jam nut, the thin nut is first tightened against the assembled parts and then the regular or high nut is tightened against the thin nut.

## 6 Materials

Table 3 specifies materials and heat treatment for the different property classes of nuts.

Nuts with coarse thread and property classes 05, 8 [regular nuts (style 1) with  $D > M16$ ], 10 and 12 shall be quenched and tempered.

Nuts with fine pitch thread and property classes 05, 6 (with  $D > M16$ ), 8 [regular nuts (style 1)], 10 and 12 shall be quenched and tempered.

The chemical composition shall be assessed in accordance with the relevant International Standards.

Table 3 — Steels

Thread	Property class		Material and nut heat treatment	Chemical composition limit (cast analysis %) <sup>a</sup>			
				C max.	Mn min.	P max.	S max.
Coarse thread	04 <sup>c</sup>		Carbon steel <sup>d</sup>	0,58	0,25	0,060	0,150
	05 <sup>c</sup>		Carbon steel, QT <sup>e</sup>	0,58	0,30	0,048	0,058
	5 <sup>b</sup>		Carbon steel <sup>d</sup>	0,58	—	0,060	0,150
	6 <sup>b</sup>		Carbon steel <sup>d</sup>	0,58	—	0,060	0,150
	8	High nut (style 2)	Carbon steel <sup>d</sup>	0,58	0,25	0,060	0,150
	8	Regular nut (style 1) $D \leq M16$	Carbon steel <sup>d</sup>	0,58	0,25	0,060	0,150
	8 <sup>c</sup>	Regular nut (style 1) $D > M16$	Carbon steel, QT <sup>e</sup>	0,58	0,30	0,048	0,058
	9		Carbon steel <sup>d</sup>	0,58	0,25	0,060	0,150
	10 <sup>c</sup>		Carbon steel, QT <sup>e</sup>	0,58	0,30	0,048	0,058
	12 <sup>c</sup>		Carbon steel, QT <sup>e</sup>	0,58	0,45	0,048	0,058
Fine pitch thread	04 <sup>b</sup>		Carbon steel <sup>d</sup>	0,58	0,25	0,060	0,150
	05 <sup>c</sup>		Carbon steel, QT <sup>e</sup>	0,58	0,30	0,048	0,058
	5 <sup>b</sup>		Carbon steel <sup>d</sup>	0,58	—	0,060	0,150
	6 <sup>b</sup>	$D \leq M16$	Carbon steel <sup>d</sup>	0,58	—	0,060	0,150
	6 <sup>b</sup>	$D > M16$	Carbon steel, QT <sup>e</sup>	0,58	0,30	0,048	0,058
	8	High nut (style 2)	Carbon steel <sup>d</sup>	0,58	0,25	0,060	0,150
	8 <sup>c</sup>	Regular nut (style 1)	Carbon steel, QT <sup>e</sup>	0,58	0,30	0,048	0,058
	10 <sup>c</sup>		Carbon steel, QT <sup>e</sup>	0,58	0,30	0,048	0,058
	12 <sup>c</sup>		Carbon steel, QT <sup>e</sup>	0,58	0,45	0,048	0,058

QT = Quenched and tempered nuts.

“—” No limit specified.

<sup>a</sup> In case of dispute, the product analysis applies.

<sup>b</sup> Nuts of these property classes may be manufactured from free-cutting steel upon agreement between the purchaser and the manufacturer; in such a case, sulfur, phosphorus and lead are permissible with the following maximum contents: S: 0,34 %; P: 0,11 %; Pb: 0,35%.

<sup>c</sup> Alloying elements may be added, provided the mechanical properties required in Clause 7 are fulfilled.

<sup>d</sup> This may be quenched and tempered at the manufacturer's discretion.

<sup>e</sup> For materials of these property classes, there shall be sufficient hardenability to ensure a structure consisting of approximately 90 % martensite in the “as-hardened” condition before tempering in the threaded area of the nut as specified in Figure 3.

NOTE It is intended that national regulations for the restriction or prohibition of certain chemical elements be taken into account in the countries or regions concerned.

## 7 Mechanical properties

When tested by the methods specified in Clause 9, the nuts of the specified property class shall meet, at ambient temperature, the requirements for the proof load (see Tables 4 and 5) and for the hardness (see Tables 6 and 7), regardless of which tests are performed during manufacturing or final inspection.

For nuts which are not quenched and tempered, 9.2.4.2 additionally applies.

Table 4 — Proof load values for nuts with coarse thread

Thread <i>D</i>	Pitch <i>P</i>	Proof load <sup>a</sup> , N							
		Property class							
		04	05	5	6	8	9	10	12
M5	0,8	5 400	7 100	8 250	9 500	12 140	13 000	14 800	16 300
M6	1	7 640	10 000	11 700	13 500	17 200	18 400	20 900	23 100
M7	1	11 000	14 500	16 800	19 400	24 700	26 400	30 100	33 200
M8	1,25	13 900	18 300	21 600	24 900	31 800	34 400	38 100	42 500
M10	1,5	22 000	29 000	34 200	39 400	50 500	54 500	60 300	67 300
M12	1,75	32 000	42 200	51 400	59 000	74 200	80 100	88 500	100 300
M14	2	43 700	57 500	70 200	80 500	101 200	109 300	120 800	136 900
M16	2	59 700	78 500	95 800	109 900	138 200	149 200	164 900	186 800
M18	2,5	73 000	96 000	121 000	138 200	176 600	176 600	203 500	230 400
M20	2,5	93 100	122 500	154 400	176 400	225 400	225 400	259 700	294 000
M22	2,5	115 100	151 500	190 900	218 200	278 800	278 800	321 200	363 600
M24	3	134 100	176 500	222 400	254 200	324 800	324 800	374 200	423 600
M27	3	174 400	229 500	289 200	330 500	422 300	422 300	486 500	550 800
M30	3,5	213 200	280 500	353 400	403 900	516 100	516 100	594 700	673 200
M33	3,5	263 700	347 000	437 200	499 700	638 500	638 500	735 600	832 800
M36	4	310 500	408 500	514 700	588 200	751 600	751 600	866 000	980 400
M39	4	370 900	488 000	614 900	702 700	897 900	897 900	1 035 000	1 171 000

<sup>a</sup> For the application of thin nuts, it should be considered that the stripping load is lower than the proof load of a nut with full loadability (see Annex A).

Table 5 — Proof load values for nuts with fine pitch thread

Thread $D \times P$	Proof load <sup>a</sup> , N						
	Property class						
	04	05	5	6	8	10	12
M8×1	14 900	19 600	27 000	30 200	37 400	43 100	47 000
M10×1,25	23 300	30 600	44 200	47 100	58 400	67 300	73 400
M10×1	24 500	32 200	44 500	49 700	61 600	71 000	77 400
M12×1,5	33 500	44 000	60 800	68 700	84 100	97 800	105 700
M12×1,25	35 000	46 000	63 500	71 800	88 000	102 200	110 500
M14×1,5	47 500	62 500	86 300	97 500	119 400	138 800	150 000
M16×1,5	63 500	83 500	115 200	130 300	159 500	185 400	200 400
M18×2	77 500	102 000	146 900	177 500	210 100	220 300	—
M18×1,5	81 700	107 500	154 800	187 000	221 500	232 200	—
M20×2	98 000	129 000	185 800	224 500	265 700	278 600	—
M20×1,5	103 400	136 000	195 800	236 600	280 200	293 800	—
M22×2	120 800	159 000	229 000	276 700	327 500	343 400	—
M22×1,5	126 500	166 500	239 800	289 700	343 000	359 600	—
M24×2	145 900	192 000	276 500	334 100	395 500	414 700	—
M27×2	188 500	248 000	351 100	431 500	510 900	535 700	—
M30×2	236 000	310 500	447 100	540 300	639 600	670 700	—
M33×2	289 200	380 500	547 900	662 100	783 800	821 900	—
M36×3	328 700	432 500	622 800	804 400	942 800	934 200	—
M39×3	391 400	515 000	741 600	957 900	1 123 000	1 112 000	—

<sup>a</sup> For the application of thin nuts, it should be considered that the stripping load is lower than the proof load of a nut with full loadability, see Annex A.

Table 6 — Hardness properties for nuts with coarse thread

Thread $D$	Property class															
	04		05		5		6		8		9		10		12	
	Vickers hardness, HV															
	min.	max.	min.	max.	min.	max.	min.	max.	min.	max.	min.	max.	min.	max.	min.	max.
$M5 \leq D \leq M16$	188	302	272	353	130	302	150	302	200	302	188	302	272	353	295 <sup>c</sup>	353
$M16 < D \leq M39$					146		170		233 <sup>a</sup>	353 <sup>b</sup>					272	
	Brinell hardness, HB															
	min.	max.	min.	max.	min.	max.	min.	max.	min.	max.	min.	max.	min.	max.	min.	max.
$M5 \leq D \leq M16$	179	287	259	336	124	287	143	287	190	287	179	287	259	336	280 <sup>c</sup>	336
$M16 < D \leq M39$					139		162		221 <sup>a</sup>	336 <sup>b</sup>					259	
	Rockwell hardness, HRC															
	min.	max.	min.	max.	min.	max.	min.	max.	min.	max.	min.	max.	min.	max.	min.	max.
$M5 \leq D \leq M16$	—	30	26	36	—	30	—	30	—	30	—	30	26	36	29 <sup>c</sup>	36
$M16 < D \leq M39$										36 <sup>b</sup>					26	

Surface integrity shall be in accordance with ISO 6157-2.

Vickers hardness test is the reference method for acceptance (see 9.2.4).

<sup>a</sup> Minimum value for high nuts (style 2): 180 HV (171 HB).

<sup>b</sup> Maximum value for high nuts (style 2): 302 HV (287 HB; 30 HRC).

<sup>c</sup> Minimum value for high nuts (style 2): 272 HV (259 HB; 26 HRC).

Table 7 — Hardness properties for nuts with fine pitch thread

Thread <i>D × P</i>	Property class													
	04		05		5		6		8		10		12	
	Vickers hardness, HV													
	min.	max.	min.	max.	min.	max.	min.	max.	min.	max.	min.	max.	min.	max.
M8×1 ≤ D ≤ M16×1,5	188	302	272	353	175	302	188	302	250 <sup>a</sup>	353 <sup>b</sup>	295 <sup>c</sup>	353	295	353
M16×1,5 < D ≤ M39×3					190		233		295	353	260		—	—
	Brinell hardness, HB													
	min.	max.	min.	max.	min.	max.	min.	max.	min.	max.	min.	max.	min.	max.
M8×1 ≤ D ≤ M16×1,5	179	287	259	336	166	287	179	287	238 <sup>a</sup>	336 <sup>b</sup>	280 <sup>c</sup>	336	280	336
M16×1,5 < D ≤ M39×3					181		221		280	336	247		—	—
	Rockwell hardness, HRC													
	min.	max.	min.	max.	min.	max.	min.	max.	min.	max.	min.	max.	min.	max.
M8×1 ≤ D ≤ M16×1,5	—	30	26	36	—	30	—	30	22,2 <sup>a</sup>	36 <sup>b</sup>	29 <sup>c</sup>	36	29	36
M16×1,5 < D ≤ M39×3					—		—		29,2	36	24		—	—
Surface integrity shall be in accordance with ISO 6157-2.														
The Vickers hardness test is the reference method for acceptance (see 9.2.4).														
<sup>a</sup> Minimum value for high nuts (style 2): 195 HV (185 HB).														
<sup>b</sup> Maximum value for high nuts (style 2): 302 HV (287 HB; 30 HRC).														
<sup>c</sup> Minimum value for high nuts (style 2): 250 HV (238 HB; 22,2 HRC).														

## 8 Inspection

### 8.1 Manufacturer’s inspection

This part of ISO 898 does not mandate which of the tests the manufacturer shall perform on each manufacturing lot. It is the responsibility of the manufacturer to apply suitable methods of his choice, such as in-process testing or inspection to ensure that the manufactured lot does indeed conform to all of the specified requirements. For additional information, see ISO 16426.

In case of dispute, the test methods according to Clause 9 shall apply.

### 8.2 Supplier’s inspection

The supplier tests the nuts which he provides using methods of their choice (periodic evaluation of the manufacturer, checking of test results from the manufacturers, tests on the nuts, etc.), provided the mechanical and physical properties specified in Tables 3, 4, 5, 6 and 7 are met.

In case of dispute, the test methods according to Clause 9 shall apply.

### 8.3 Purchaser’s inspection

The purchaser may test the delivered nuts using the test methods specified in Clause 9.

In case of dispute, the test methods according to Clause 9 shall apply, unless otherwise specified.

## 9 Test methods

### 9.1 Proof load test

#### 9.1.1 General

The proof load test consists of two main operations, namely

- a) application of a specified proof load by means of a test mandrel (see Figures 1 and 2), and
- b) checking of the damage to the nut thread caused by the proof load, if any.

NOTE For the proof load test for prevailing torque type nuts, see ISO 2320 for an additional test procedure.

#### 9.1.2 Applicability

This test applies to nuts with nominal diameters  $M5 \leq D \leq M39$  and for all property classes.

#### 9.1.3 Apparatus

The tensile testing machine shall be in accordance with ISO 7500-1, class 1 or better. Side thrust on the nut shall be avoided, e.g. by self-aligning grips.

#### 9.1.4 Testing device

The grips and test mandrel shall fulfil the following requirements:

- a) hardness of the grip: 45 HRC minimum;
- b) thickness,  $h$ , of the grip:  $1D$  minimum;
- c) hole diameter,  $d_h$ , of the grip: according to Table 8;
- d) mandrel hardened and tempered: hardness 45 HRC to 50 HRC;
- e) external thread tolerance class of the test mandrel: mandrels used shall be threaded to tolerance class 5h6g except that the tolerance of the major diameter shall be the last quarter of the 6g range on the minimum material side. Thread dimensions for the test mandrel are given in Tables B.1 and B.2.

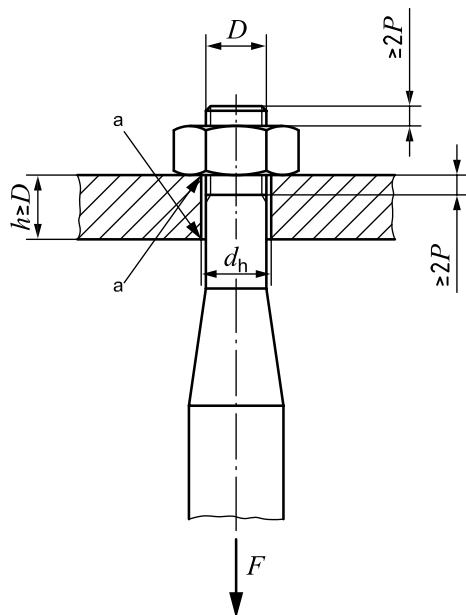

a No sharp edge.

Figure 1 — Axial tensile test

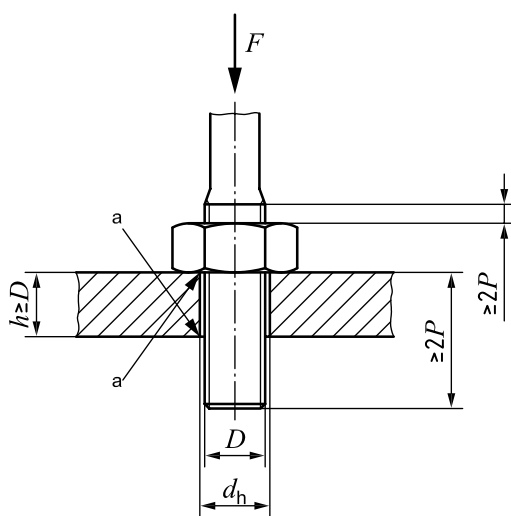

a No sharp edge.

Figure 2 — Axial compressive test

Table 8 — Hole diameter for the grip

Dimensions in millimetres

Nominal diameter <i>D</i>	Hole diameter <i>d<sub>h</sub><sup>a</sup></i>		Nominal diameter <i>D</i>	Hole diameter <i>d<sub>h</sub><sup>a</sup></i>		Nominal diameter <i>D</i>	Hole diameter <i>d<sub>h</sub><sup>a</sup></i>	
	min.	max.		min.	max.		min.	max.
M5	5,030	5,115	M14	14,050	14,160	M27	27,065	27,195
M6	6,030	6,115	M16	16,050	16,160	M30	30,065	30,195
M7	7,040	7,130	M18	18,050	18,160	M33	33,080	33,240
M8	8,040	8,130	M20	20,065	20,195	M36	36,080	36,240
M10	10,040	10,130	M22	22,065	22,195	M39	39,080	39,240
M12	12,050	12,160	M24	24,065	24,195	—	—	—

<sup>a</sup>  $d_h = D$  with tolerance class D11 (see ISO 286-2).

### 9.1.5 Test procedure

The nut shall be tested as received.

The nut shall be assembled on the test mandrel according to Figure 1 or Figure 2.

The axial tensile test or axial compressive test shall be carried out in accordance with ISO 6892-1. The speed of testing, as determined with a free-running cross-head, shall not exceed 3 mm/min.

The proof load specified in Table 4 for nuts with coarse thread and in Table 5 for fine pitch thread shall be applied and shall be maintained for 15 s and then released.

Exceeding the proof load value should be minimized.

The nut shall be removed using the fingers from the test mandrel. It may be necessary to use a manual wrench to start the nut in motion, but the use of such a wrench is permissible only to a half turn.

The test mandrel threads shall be checked after each tested nut. If the thread of the test mandrel is damaged during the test, the test result shall not be valid and a new test shall be carried out with a conforming mandrel.

### 9.1.6 Test results

The fact that nut fracture or thread stripping occurs shall be noted.

The fact that the nut has been removed only with the fingers or with the help of a wrench to one half turn maximum shall be noted.

### 9.1.7 Requirements

The nut shall resist the proof load specified in Table 4 or Table 5 without fracture by thread stripping or nut fracture.

The nut shall be removable using the fingers after the release of the proof load (and, if necessary, after a half turn maximum with a wrench).

In case of dispute, the axial tensile test, in accordance with Figure 1, shall be the reference method for acceptance.

## 9.2 Hardness test

### 9.2.1 Applicability

This test applies to nuts of all sizes and of all property classes.

**9.2.2 Test methods**

Hardness may be determined using the Vickers, Brinell or Rockwell hardness test.

The Vickers hardness test shall be carried out in accordance with ISO 6507-1. The Brinell hardness test shall be carried out in accordance with ISO 6506-1. The Rockwell hardness test shall be carried out in accordance with ISO 6508-1.

**9.2.3 Test procedures**

**9.2.3.1 Test load for hardness determination**

The Vickers hardness test shall be carried out with a minimum load of 98 N.

The Brinell hardness test shall be carried out with a load equal to  $30D^2$ , expressed in newtons.

**9.2.3.2 Hardness determined on a surface**

For routine inspection, the hardness test shall be carried out on one bearing surface of the nut, after removal of any plating or other coating and after suitable preparation of the nut.

The hardness value shall be the mean of three readings spaced about 120° apart.

**9.2.3.3 Hardness determined on a longitudinal section**

The hardness test shall be carried out on a longitudinal section through the nut axis. The readings shall be located at a height of about  $0,5m$  and placed as close as possible to the nominal major diameter of the nut thread; see Figure 3.

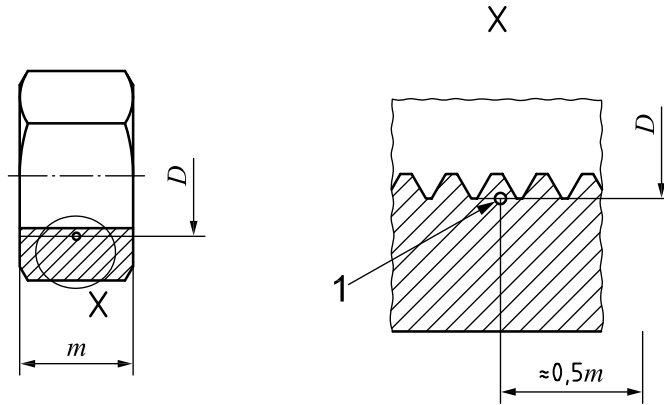

**Key**

1 location of hardness reading

**Figure 3 — Location of hardness readings at about mid-height position of the nut**

**9.2.4 Requirements**

**9.2.4.1 Quenched and tempered nuts**

Surface hardness according to 9.2.3.2 shall meet the requirements specified in Table 6 for nuts with coarse thread and in Table 7 for nuts with fine pitch thread.

In case of dispute:

- a) for surface hardness according to 9.2.3.2, Vickers hardness test with a load of 98 N (HV 10) shall be the reference test method and the hardness shall meet the requirements specified in Table 6 or Table 7;

- b) for core hardness, Vickers hardness test according to 9.2.3.3 shall be the reference test method and the hardness shall meet the requirements specified in Table 6 or Table 7.

#### **9.2.4.2 Non-quenched and tempered nuts**

Nuts which are not quenched and tempered shall not exceed the maximum hardness requirement according to Table 6 or Table 7. In case of dispute, Vickers hardness determination according to 9.2.3.3 shall be the reference test method.

If the minimum hardness requirement is not met when tested according to 9.2.3.2 or 9.2.3.3, this shall not be cause for rejection, provided the proof load requirements according to 9.1.7 are met.

### **9.3 Surface integrity inspection**

The surface discontinuity inspection shall be as specified in ISO 6157-2.

## **10 Marking**

### **10.1 General**

Only those nuts meeting all relevant requirements of this part of ISO 898 shall be designated in accordance with the designation system specified in 4.2 and marked in accordance with 10.2 to 10.6.

Alternative marking specified in Table 9 should be left to the discretion of the manufacturer.

### **10.2 Identification mark of the manufacturer**

An identification mark of the manufacturer shall be included during the manufacturing process on all nuts which are marked with a property class symbol. The identification marking of the manufacturer is also recommended on nuts which are not marked with a property class symbol.

For the purpose of this part of ISO 898, a distributor who distributes nuts that are marked with his own identification mark shall be considered to be the manufacturer.

### **10.3 Marking of property classes**

#### **10.3.1 General**

The marking symbol in accordance with 10.3.2 to 10.5 shall be embossed or indented, during the manufacturing process, on all nuts manufactured to the requirements of this part of ISO 898.

#### **10.3.2 Regular nuts (style 1) and high nuts (style 2)**

The marking symbols for property classes for regular nuts (style 1) and high nuts (style 2) are specified in the second row of Table 9. In the case of small nuts or where the shape of the nut does not allow that marking, the clock face marking symbols given in the third row of Table 9 shall be used.

**Table 9 — Marking symbols of property classes for regular nuts (style 1) and high nuts (style 2)**

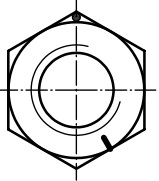
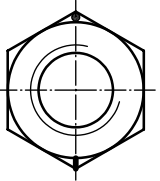
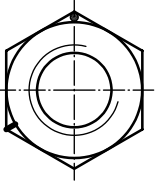
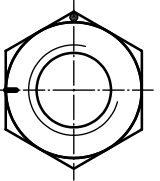
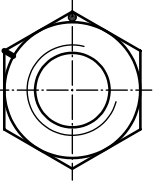
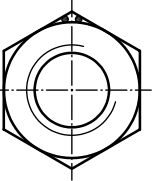
<b>Property class designation symbol</b>	<b>5</b>	<b>6</b>	<b>8</b>	<b>9</b>	<b>10</b>	<b>12</b>
<b>Marking symbol</b>	<b>5</b>	<b>6</b>	<b>8</b>	<b>9</b>	<b>10</b>	<b>12</b>
<b>Alternative clock face marking symbol<sup>a</sup></b>						
<sup>a</sup> The twelve o'clock position (reference mark) shall be marked either by the identification mark of the manufacturer or by a dot.						

**10.3.3 Thin nuts (style 0)**

Marking symbols for property classes for thin nuts (style 0) are specified in Table 10.

**Table 10 — Marking symbols of property classes for thin nuts (style 0)**

<b>Property class</b>	<b>04</b>	<b>05</b>
<b>Marking symbol</b>	04	05

The alternative clock face marking according to Table 9 shall not be used for thin nuts.

**10.4 Identification**

**10.4.1 Hexagon nuts**

Hexagon nuts (including nuts with flange, prevailing torque type nuts, etc.) shall be marked with the identification mark of the manufacturer and with the marking symbol of the property class specified in Table 9. Examples are shown in Figures 4 and 5.

The marking is required for nuts of all property classes.

The marking shall comprise indentation on the side or bearing surface or embossing on the chamfer. Embossed marks shall not protrude beyond the bearing surface of the nut.

In the case of nuts with flange, marking shall be on the flange where the manufacturing process does not allow marking on the top of the nut.

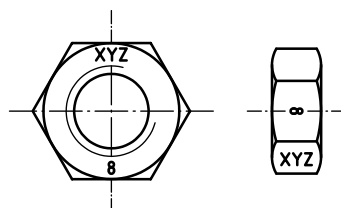

**Figure 4 — Examples of marking symbol**

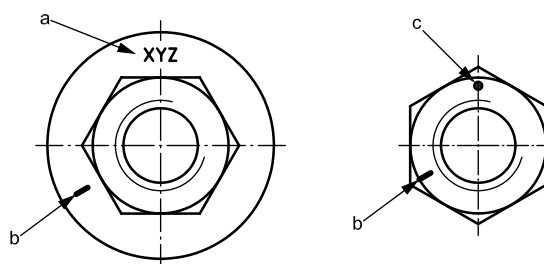

- a Identification mark of the manufacturer.
- b Property class.
- c The dot may be replaced by the identification mark of the manufacturer.

**Figure 5 — Examples of marking with clock-face system (alternative marking)**

#### 10.4.2 Other type of nuts

If required by the purchaser, the same marking systems as specified in 10.4.1 shall be used for other types of nuts.

#### 10.5 Marking of left-hand thread

Nuts with left-hand thread shall be marked as specified in Figure 6 on one bearing surface of the nut by indentation.

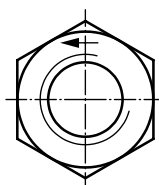

**Figure 6 — Marking of left-hand thread**

Alternative marking for left-hand thread as specified in Figure 7 may also be used for hexagon nuts.

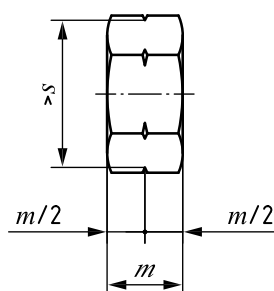

#### Key

*s* width across flats

*m* height of the nut

**Figure 7 — Alternative marking of left-hand thread**

#### 10.6 Marking of packages

All packages for all types of nuts of all sizes shall be marked (e.g. using labelling). The marking shall include the manufacturer's and/or distributor's identification and the marking symbol for the property class according to Table 9 or Table 10 and the manufacturing lot number as defined in ISO 16426.

## Annex A (informative)

### Design principles of nuts

#### A.1 Basic design principles of nuts

A bolted joint basically consists of two workpieces, which are clamped together using an externally threaded part (bolt or screw) on one side and an internally threaded part or a nut on the other side.

An optimized bolted joint, consisting of a bolt, screw or stud of a given property class according to ISO 898-1 assembled with a regular or high nut of the mating property class according to this part of ISO 898 is able to provide a maximum preload, using the full strength of the bolt. In the case of over-tightening, the fracture occurs in the loaded threaded part of the bolt, which gives an obvious indication of a tightening failure.

Under tensile load, the fracture mode of bolt and nut assemblies corresponds to the lowest value of the following three loads:

- a) thread stripping load in the nut;
- b) thread stripping load in the bolt, screw or stud;
- c) breaking load in the bolt, screw or stud. (Bolt breaking is the intended fracture mode of bolt and nut assemblies in case of overloading.)

These three loads mainly depend on:

- hardness, height, effective length of the full thread, diameter, pitch and thread tolerance class of the nut,
- hardness, diameter, pitch and thread tolerance class of the bolt.

Furthermore, these three loads are linked. For example, an increase of hardness of the bolt can induce an increase of the thread stripping load in the nut. The hardness also determines the functional toughness of the nut and, therefore, an upper limit is specified for each property class.

The analytical basis for the calculation of the different stripping loads has been worked out in the publication by Alexander<sup>[14]</sup>. Extensive experimental tests proved Alexander's theory through practical results. Actual studies, including FEM-based calculations, confirmed Alexander's theory<sup>[15]</sup>.

The three styles of nut (see 4.1) are distinguished by their heights. This gives the manufacturer for certain property classes the option of using a quench and tempering process with less material to achieve the required properties, or using more material without any additional heat treatment.

Table A.1 — Minimum heights of hexagon nuts

Thread <i>D</i>	Width across flats <i>s</i> mm	Minimum height of hexagon nut			
		Regular nut (style 1)		High nut (style 2)	
		$m_{\min}$ mm	$m_{\min}/D$	$m_{\min}$ mm	$m_{\min}/D$
M5	8	4,40	0,88	4,80	0,96
M6	10	4,90	0,82	5,40	0,90
M7	11	6,14	0,88	6,84	0,98
M8	13	6,44	0,81	7,14	0,90
M10	16	8,04	0,80	8,94	0,89
M12	18	10,37	0,86	11,57	0,96
M14	21	12,10	0,86	13,40	0,96
M16	24	14,10	0,88	15,70	0,98
M18	27	15,10	0,84	16,90	0,94
M20	30	16,90	0,85	19,00	0,95
M22	34	18,10	0,82	20,50	0,93
M24	36	20,20	0,84	22,60	0,94
M27	41	22,50	0,83	25,40	0,94
M30	46	24,30	0,81	27,30	0,91
M33	50	27,40	0,83	30,90	0,94
M36	55	29,40	0,82	33,10	0,92
M39	60	31,80	0,82	35,90	0,92

For detailed technical information on the design principle of nuts, see ISO/TR 16224.

## A.2 Nuts with diameters $D < M5$ and $D > M39$

Mechanical properties of bolt and nut assemblies have been optimized for fasteners with threads from M5 to M39 inclusive, on the basis of hexagon nut dimensions specified in ISO 4032 (regular nuts, style 1) and ISO 4033 (high nuts, style 2). In general, the bolt and nut assemblies with smaller diameter need lower nut hardness and/or lower nut height proportion ( $m/D$ ) due to the larger ratio of  $P/D$ .

Nuts with  $D < 5$  mm specified in ISO 4032 have a minimum height of the nut,  $m_{\min}$ , less than  $0,8D$ , which is too low to be in accordance with this design principle. This means that such nuts need a higher hardness value to avoid the thread stripping fracture mode (see Table A.2).

Table A.2 — Minimum Vickers hardness suggested for regular nuts (style 1) with  $D < M5$ 

Thread $D$	Minimum Vickers hardness of nuts				
	HV				
	Property class				
	5	6	8	10	12
M3	151	178	233	284	347
M3,5	157	184	240	294	357
M4	147	174	228	277	337

Nuts with  $D > M39$  specified in ISO 4032 have a minimum height of the nut,  $m_{\min}$ , less than  $0,8D$ , which is too low to be in accordance with this design principle. Therefore, mechanical properties for these nuts are not defined in this part of ISO 898 and property classes are not specified in ISO 4032 (mechanical properties are by agreement between the purchaser and the supplier).

## Annex B (informative)

### Thread dimensions for the test mandrel

**Table B.1 — Thread dimensions of the proof load test mandrel — Coarse thread**

Nut Thread <i>D</i>	Mandrel (coarse thread)			
	External thread diameter of the mandrel (lowest quarter of tolerance class 6g)		Pitch diameter of the mandrel (tolerance class 5h)	
	max.	min.	max.	min.
M3	2,901	2,874	2,675	2,615
M3,5	3,385	3,354	3,110	3,043
M4	3,873	3,838	3,545	3,474
M5	4,864	4,826	4,480	4,405
M6	5,839	5,794	5,350	5,260
M7	6,839	6,794	6,350	6,260
M8	7,813	7,760	7,188	7,093
M10	9,791	9,732	9,026	8,920
M12	11,767	11,701	10,863	10,745
M14	13,752	13,682	12,701	12,576
M16	15,752	15,682	14,701	14,576
M18	17,707	17,623	16,376	16,244
M20	19,707	19,623	18,376	18,244
M22	21,707	21,623	20,376	20,244
M24	23,671	23,577	22,051	21,891
M27	26,671	26,577	25,051	24,891
M30	29,628	29,522	27,727	27,557
M33	32,628	32,522	30,727	30,557
M36	35,584	35,465	33,402	33,222
M39	38,584	38,465	36,402	36,222

Table B.2 — Thread dimensions of the proof load test mandrel — Fine pitch thread

Nut Thread <i>D × P</i>	Mandrel (fine pitch thread)			
	External thread diameter of the mandrel (lowest quarter of tolerance class 6g)		Pitch diameter of the mandrel (tolerance class 5h)	
	max.	min.	max.	min.
M8×1	7,839	7,794	7,350	7,260
M10×1,25	9,813	9,760	9,188	9,093
M10×1	9,839	9,794	9,350	9,260
M12×1,5	11,791	11,732	11,026	10,914
M12×1,25	11,813	11,760	11,188	11,082
M14×1,5	13,791	13,732	13,026	12,911
M16×1,5	15,791	15,732	15,026	14,914
M18×2	17,752	17,682	16,701	16,569
M18×1,5	17,791	17,732	17,026	16,914
M20×2	19,752	19,682	18,701	18,569
M20×1,5	19,791	19,732	19,026	18,914
M22×2	21,752	21,682	20,701	20,569
M22×1,5	21,791	21,732	21,026	20,914
M24×2	23,752	23,682	22,701	22,569
M27×2	26,752	26,682	25,701	25,569
M30×2	29,752	29,682	28,701	28,569
M33×2	32,752	32,682	31,701	31,569
M36×3	35,671	35,577	34,051	33,891
M39×3	38,671	38,577	37,051	36,891

## Bibliography

- [1] ISO 68-1, *ISO general purpose screw threads — Basic profile — Part 1: Metric screw threads*
- [2] ISO 261, *ISO general purpose metric screw threads — General plan*
- [3] ISO 262, *ISO general purpose metric screw threads — Selected sizes for screws, bolts and nuts*
- [4] ISO 286-2, *Geometrical product specifications (GPS) — ISO code system for tolerances in linear sizes — Part 2: Table of standard tolerance classes and limit deviations for holes and shafts*
- [5] ISO 2320, *Prevailing torque type steel nuts — Mechanical and performance properties*
- [6] ISO 4032, *Hexagon nuts, style 1 — Product grades A and B*
- [7] ISO 4033, *Hexagon nuts, style 2 — Product grades A and B*
- [8] ISO 10684, *Fasteners — Hot dip galvanized coatings*
- [9] ISO 16047, *Fasteners — Torque/clamp force testing*
- [10] ISO/TR 16224, *Technical aspects of nut design*
- [11] EN 10269, *Steels and nickel alloys for fasteners with specified elevated and/or low temperature properties*
- [12] ASTM A320/A320M, *Standard Specification for Alloy-Steel and Stainless Steel Bolting for Low-Temperature Service*
- [13] ASTM F2281, *Standard Specification for Stainless Steel and Nickel Alloy Bolts, Hex Cap Screws, and Studs, for Heat Resistance and High Temperature Applications*
- [14] Alexander, E.M., *Analysis and design of threaded assemblies*. 1977 *SAE Transactions*, Paper No. 770420
- [15] Hagiwara, M., Hiroaki, S. *Verification of the Design Concept in Bolt/Nut Assemblies for the revision of ISO 898-2 and ISO 898-6*, *Journal of Advanced Mechanical Design, Systems, and Manufacturing*, vol. 1, no. 5, 2007, pp. 755–762.

