**Mechanical properties of fasteners made
of carbon steel and alloy steel**

Part 1:
**Bolts, screws and studs with specified
property classes — Coarse thread and
fine pitch thread**

*Caractéristiques mécaniques des éléments de fixation en acier au
carbone et en acier allié*

*Partie 1: Vis, goujons et tiges filetées de classes de qualité
spécifiées — Filetages à pas gros et filetages à pas fin*



Reference number
ISO 898-1:2013(E)

© ISO 2013



COPYRIGHT PROTECTED DOCUMENT

© ISO 2013

All rights reserved. Unless otherwise specified, no part of this publication may be reproduced or utilized in any form or by any means, electronic or mechanical, including photocopying and microfilm, without permission in writing from either ISO at the address below or ISO's member body in the country of the requester.

ISO copyright office
Case postale 56 • CH-1211 Geneva 20
Tel. + 41 22 749 01 11
Fax + 41 22 749 09 47
E-mail copyright@iso.org
Web www.iso.org

Published in Switzerland

Contents

Page

Foreword	iv
1 Scope	1
2 Normative references	2
3 Terms and definitions	3
4 Symbols and abbreviated terms	4
5 Designation system for property classes	6
6 Materials	6
7 Mechanical and physical properties.....	8
8 Applicability of test methods	12
8.1 General	12
8.2 Loadability of fasteners	12
8.3 Manufacturer's test/inspection	13
8.4 Supplier's test/inspection	13
8.5 Purchaser's test/inspection.....	13
8.6 Feasible tests for groups of fasteners and machined test pieces	14
9 Test methods	21
9.1 Tensile test under wedge loading of finished bolts and screws (excluding studs).....	21
9.2 Tensile test for finished bolts, screws and studs for determination of tensile strength, R_m	25
9.3 Tensile test for full-size bolts, screws and studs for determination of elongation after fracture, A_f , and stress at 0,0048d non-proportional elongation, R_{pf}	27
9.4 Tensile test for bolts and screws with reduced loadability due to head design	31
9.5 Tensile test for fasteners with waisted shank.....	32
9.6 Proof load test for finished bolts, screws and studs.....	33
9.7 Tensile test for machined test pieces	35
9.8 Head soundness test	38
9.9 Hardness test.....	39
9.10 Decarburization test	41
9.11 Carburization test	44
9.12 Retempering test	46
9.13 Torsional test	46
9.14 Impact test for machined test pieces	47
9.15 Surface discontinuity inspection	48
10 Marking	48
10.1 General	48
10.2 Manufacturer's identification mark.....	49
10.3 Marking and identification of fasteners with full loadability.....	49
10.4 Marking and designation of fasteners with reduced loadability	53
10.5 Marking of packages	53
Annex A (informative) Relationship between tensile strength and elongation after fracture.....	54
Annex B (informative) Influence of elevated temperatures on mechanical properties of fasteners.....	55
Annex C (informative) Elongation after fracture for full-size fasteners, A_f	56
Bibliography.....	57

Foreword

ISO (the International Organization for Standardization) is a worldwide federation of national standards bodies (ISO member bodies). The work of preparing International Standards is normally carried out through ISO technical committees. Each member body interested in a subject for which a technical committee has been established has the right to be represented on that committee. International organizations, governmental and non-governmental, in liaison with ISO, also take part in the work. ISO collaborates closely with the International Electrotechnical Commission (IEC) on all matters of electrotechnical standardization.

International Standards are drafted in accordance with the rules given in the ISO/IEC Directives, Part 2.

The main task of technical committees is to prepare International Standards. Draft International Standards adopted by the technical committees are circulated to the member bodies for voting. Publication as an International Standard requires approval by at least 75 % of the member bodies casting a vote.

Attention is drawn to the possibility that some of the elements of this document may be the subject of patent rights. ISO shall not be held responsible for identifying any or all such patent rights.

ISO 898-1 was prepared by Technical Committee ISO/TC 2, *Fasteners*, Subcommittee SC 11, *Fasteners with metric external thread*.

This fifth edition cancels and replaces the fourth edition (ISO 898-1:2009), of which it constitutes a minor revision.

ISO 898 consists of the following parts, under the general title *Mechanical properties of fasteners made of carbon steel and alloy steel*:

- *Part 1: Bolts, screws and studs with specified property classes — Coarse thread and fine pitch thread*
- *Part 2: Nuts with specified property classes — Coarse thread and fine pitch thread*
- *Part 5: Set screws and similar threaded fasteners with specified hardness classes — Coarse thread and fine pitch thread*
- *Part 7: Torsional test and minimum torques for bolts and screws with nominal diameters 1 mm to 10 mm¹⁾*

¹⁾ It is intended that, upon revision, the main element of the title of Part 7 will be aligned with the main element of the titles of Parts 1 to 5.

Mechanical properties of fasteners made of carbon steel and alloy steel

Part 1: Bolts, screws and studs with specified property classes — Coarse thread and fine pitch thread

1 Scope

This part of ISO 898 specifies mechanical and physical properties of bolts, screws and studs made of carbon steel and alloy steel when tested at an ambient temperature range of 10 °C to 35 °C. Fasteners (the term used when bolts, screws and studs are considered all together) that conform to the requirements of this part of ISO 898 are evaluated at that ambient temperature range. They might not retain the specified mechanical and physical properties at elevated temperatures (see Annex B) and/or lower temperatures.

NOTE 1 Fasteners conforming to the requirements of this part of ISO 898 are used in applications ranging from –50 °C to +150 °C. Users are advised to consult an experienced fastener metallurgist for temperatures outside the range of –50 °C to +150 °C and up to a maximum temperature of +300 °C when determining appropriate choices for a given application.

NOTE 2 Information for the selection and application of steels for use at lower and elevated temperatures is given, for example, in EN 10269, ASTM F2281 and in ASTM A320/A320M.

Certain bolts and screws might not fulfil the tensile or torsional requirements of this part of ISO 898 because the geometry of their heads reduces the shear area in the head compared to the stress area in the thread. These include bolts and screws having a low or countersunk head (see 8.2).

This part of ISO 898 is applicable to bolts, screws and studs

- made of carbon steel or alloy steel,
- having triangular ISO metric screw thread in accordance with ISO 68-1,
- with coarse pitch thread M1,6 to M39, and fine pitch thread M8×1 to M39×3,
- with diameter/pitch combinations in accordance with ISO 261 and ISO 262, and
- having thread tolerances in accordance with ISO 965-1, ISO 965-2 and ISO 965-4.

It is not applicable to set screws and similar threaded fasteners not under tensile stress (see ISO 898-5).

It does not specify requirements for such properties as

- weldability,
- corrosion resistance,
- resistance to shear stress,

- torque/clamp force performance (for test method, see ISO 16047), or
- fatigue resistance.

2 Normative references

The following documents, in whole or in part, are normatively referenced in this document and are indispensable to its application. For dated references, only the edition cited applies. For undated references, the latest edition of the referenced document (including any amendments) applies.

ISO 68-1, *ISO general purpose screw threads — Basic profile — Part 1: Metric screw threads*

ISO 148-1, *Metallic materials — Charpy pendulum impact test — Part 1: Test method*

ISO 225, *Fasteners — Bolts, screws, studs and nuts — Symbols and descriptions of dimensions*

ISO 261, *ISO general purpose metric screw threads — General plan*

ISO 262, *ISO general purpose metric screw threads — Selected sizes for screws, bolts and nuts*

ISO 273, *Fasteners — Clearance holes for bolts and screws*

ISO 724, *ISO general-purpose metric screw threads — Basic dimensions*

ISO 898-2, *Mechanical properties of fasteners made of carbon steel and alloy steel — Part 2: Nuts with specified property classes — Coarse thread and fine pitch thread*

ISO 898-5, *Mechanical properties of fasteners made of carbon steel and alloy steel — Part 5: Set screws and similar threaded fasteners with specified hardness classes — Coarse thread and fine pitch thread*

ISO 898-7, *Mechanical properties of fasteners — Part 7: Torsional test and minimum torques for bolts and screws with nominal diameters 1 mm to 10 mm¹⁾*

ISO 965-1, *ISO general-purpose metric screw threads — Tolerances — Part 1: Principles and basic data*

ISO 965-2, *ISO general purpose metric screw threads — Tolerances — Part 2: Limits of sizes for general purpose external and internal screw threads — Medium quality*

ISO 965-4, *ISO general purpose metric screw threads — Tolerances — Part 4: Limits of sizes for hot-dip galvanized external screw threads to mate with internal screw threads tapped with tolerance position H or G after galvanizing*

ISO 4042, *Fasteners — Electroplated coatings*

ISO 6157-1, *Fasteners — Surface discontinuities — Part 1: Bolts, screws and studs for general requirements*

ISO 6157-3, *Fasteners — Surface discontinuities — Part 3: Bolts, screws and studs for special requirements*

ISO 6506-1, *Metallic materials — Brinell hardness test — Part 1: Test method*

ISO 6507-1, *Metallic materials — Vickers hardness test — Part 1: Test method*

ISO 6508-1, *Metallic materials — Rockwell hardness test — Part 1: Test method (scales A, B, C, D, E, F, G, H, K, N, T)*

ISO 6892-1, *Metallic materials — Tensile testing — Part 1: Method of test at room temperature*

ISO 7500-1, *Metallic materials — Verification of static uniaxial testing machines — Part 1: Tension/compression testing machines — Verification and calibration of the force-measuring system*

ISO 10683, *Fasteners — Non-electrolytically applied zinc flake coatings*

ISO 10684:2004, *Fasteners — Hot dip galvanized coatings*

ISO 16426, *Fasteners — Quality assurance system*

3 Terms and definitions

For the purposes of this document, the following terms and definitions apply.

3.1

finished fastener

fastener for which all manufacturing steps have been completed, with or without any surface coating and with full or reduced loadability, and which has not been machined into a test piece

3.2

machined test piece

test piece machined from a fastener to evaluate material properties

3.3

full-size fastener

finished fastener with a shank diameter of $d_s \approx d$ or $d_s > d$, or screw threaded to the head, or fully threaded stud

3.4

fastener with reduced shank

finished fastener with a shank diameter of $d_s \approx d_2$

3.5

fastener with waisted shank

finished fastener with a shank diameter of $d_s < d_2$

3.6

base metal hardness

hardness closest to the surface (when traversing from core to outside diameter) just before an increase or decrease occurs, denoting, respectively, carburization or decarburization

3.7

carburization

result of increasing surface carbon to a content above that of the base metal

3.8

decarburization

loss of carbon at the surface of a steel fastener

3.9

partial decarburization

decarburization with sufficient loss of carbon to cause a lighter shade of tempered martensite and a significantly lower hardness than that of the adjacent base metal, without, however, showing ferrite grains under metallographic examination

3.10

ferritic decarburization

decarburization with sufficient loss of carbon to cause a lighter shade of tempered martensite and a significantly lower hardness than that of the adjacent base metal, with the presence of ferrite grains or grain boundary network under metallographic examination

3.11

complete decarburization

decarburization with sufficient carbon loss to show only clearly defined ferrite grains under metallographic examination

4 Symbols and abbreviated terms

For the purposes of this document, the symbols and abbreviated terms given in ISO 225 and ISO 965-1, and the following apply.

A	Percentage elongation after fracture (of machined test piece), %
A_f	Elongation after fracture for full-size fastener
$A_{s,nom}$	Nominal stress area in thread, mm ²
A_{ds}	Cross-sectional area of waisted shank, mm ²
b	Thread length, mm
b_m	Thread length of stud metal end, mm
d	Nominal thread diameter, mm
d_0	Diameter of machined test piece, mm
d_1	Basic minor diameter of external thread, mm
d_2	Basic pitch diameter of external thread, mm
d_3	Minor diameter of external thread, mm
d_a	Transition diameter (internal diameter of the bearing face), mm
d_h	Hole diameter of wedge or block, mm
d_s	Diameter of unthreaded shank, mm
E	Height of non-decarburized zone in thread, mm
F_m	Ultimate tensile load, N
$F_{m,min}$	Minimum ultimate tensile load, N
F_p	Proof load, N
F_{pf}	Load at 0,0048d non-proportional elongation for full-size fastener, N
G	Depth of complete decarburization in thread, mm
H	Height of fundamental triangle, mm
H_1	Height of external thread in maximum material condition, mm
k	Height of the head, mm
K_v	Impact strength, J

l	Nominal length, mm
l_0	Total length of fastener before loading, mm
l_1	Total length of fastener after first unloading, mm
l_2	Total length of fastener after second unloading, mm
l_s	Length of unthreaded shank, mm
l_t	Overall length of stud, mm
l_{th}	Free threaded length of fastener in testing device, mm
L_c	Length of straight portion (of machined test piece), mm
L_o	Original gauge length (of machined test piece), mm
L_t	Total length of machined test piece, mm
L_u	Final gauge length (of machined test piece), mm
ΔL_p	Plastic elongation, mm
M_B	Breaking torque, Nm
P	Pitch of thread, mm
r	Fillet radius, mm
R_{eL}	Lower yield strength for machined test piece, MPa
R_m	Tensile strength, MPa
$R_{p0,2}$	Stress at 0,2 % non-proportional elongation for machined test piece, MPa
R_{pf}	Stress at 0,0048d non-proportional elongation for full-size fastener, MPa
s	Width across flats, mm
S_o	Cross-sectional area of machined test piece before tensile test, mm ²
S_p	Stress under proof load, MPa
S_u	Cross-sectional area of machined test piece after fracture, mm ²
Z	Percentage reduction of area after fracture for machined test piece, %
α	Wedge angle for tensile test under wedge loading
β	Angle of the solid block for head soundness test
max	Subscript added to symbol to denote maximum value
min	Subscript added to symbol to denote minimum value
nom	Subscript added to symbol to denote nominal value

5 Designation system for property classes

The symbol for property classes of bolts, screws, and studs consists of two numbers, separated by a dot (see Tables 1 to 3):

- a) the number to the left of the dot consists of one or two digits and indicates 1/100 of the nominal tensile strength, $R_{m,nom}$, in megapascals (see Table 3, No. 1);
- b) the number to the right of the dot indicates 10 times the ratio between the nominal yield strength and the nominal tensile strength, $R_{m,nom}$, as specified in Table 1 (yield strength ratio). The nominal yield strength, as specified in Table 3 (Nos. 2 to 4), is:
 - lower yield strength $R_{eL,nom}$, or
 - nominal stress at 0,2 % non-proportional elongation $R_{p0,2,nom}$, or
 - nominal stress at 0,0048d non-proportional elongation $R_{pf,nom}$.

Table 1 — Ratio of nominal yield strength and nominal tensile strength

Number to the right of dot	.6	.8	.9
$\frac{R_{eL,nom}}{R_{m,nom}}$ or $\frac{R_{p0,2,nom}}{R_{m,nom}}$ or $\frac{R_{pf,nom}}{R_{m,nom}}$	0,6	0,8	0,9

- c) an additional zero to the left of the property class designation indicates that fasteners have reduced loadability (see 8.2 and 10.4).

EXAMPLE 1 A fastener of nominal tensile strength $R_{m,nom} = 800$ MPa and with a yield strength ratio of 0,8 has the property class designation 8.8.

EXAMPLE 2 A fastener with material properties of property class 8.8 but with reduced loadability is designated by 08.8.

The multiplication of the nominal tensile strength and the yield strength ratio gives the nominal yield strength in megapascals (MPa).

Marking and labelling of bolts, screws and studs with property classes shall be as specified in 10.3. For fasteners with reduced loadability, specific marking symbols are specified in 10.4.

The designation system of this part of ISO 898 may be applied to sizes outside the scope of this part of ISO 898 (e.g. $d > 39$ mm), provided all applicable requirements in accordance with Tables 2 and 3 are met.

Information on the relationship between the nominal tensile strength and elongation after fracture for each property class is given in Annex A.

6 Materials

Table 2 specifies limits for the chemical composition of steels and minimum tempering temperatures for the different property classes of bolts, screws and studs. The chemical composition shall be assessed in accordance with the relevant International Standards.

NOTE National regulations for the restriction or prohibition of certain chemical elements might also have to be taken into account in the countries or regions concerned.

For fasteners that are to be hot dip galvanized, the additional material requirements given in ISO 10684 apply.

Table 2 — Steels

Property class	Material and heat treatment	Chemical composition limit (cast analysis, %) ^a				B ^b max.	Tempering temperature °C min.
		C min.	C max.	P max.	S max.		
4.6^{c,d}	Carbon steel or carbon steel with additives	—	0,55	0,050	0,060	Not specified	—
4.8^d		0,13	0,55	0,050	0,060		
5.6^c		—	0,55	0,050	0,060		
5.8^d		0,15	0,55	0,050	0,060		
6.8^d		0,15 ^e	0,40	0,025	0,025		
8.8^f	Carbon steel with additives (e.g. Boron or Mn or Cr) quenched and tempered	0,25	0,55	0,025	0,025	0,003	425
	or Carbon steel quenched and tempered	0,20	0,55	0,025	0,025		
	or Alloy steel quenched and tempered ^g	0,20	0,55	0,025	0,025		
9.8^f	Carbon steel with additives (e.g. Boron or Mn or Cr) quenched and tempered	0,25	0,55	0,025	0,025	0,003	425
	or Carbon steel quenched and tempered	0,20	0,55	0,025	0,025		
	or Alloy steel quenched and tempered ^g	0,20	0,55	0,025	0,025		
10.9^f	Carbon steel with additives (e.g. Boron or Mn or Cr) quenched and tempered	0,20 ^e	0,55	0,025	0,025	0,003	425
	or Carbon steel quenched and tempered	0,25	0,55	0,025	0,025		
	or Alloy steel quenched and tempered ^g	0,20	0,55	0,025	0,025		
12.9^{f,hi}	Alloy steel quenched and tempered ^g	0,30	0,50	0,025	0,025	0,003	425
12.9^{f,hi}	Carbon steel with additives (e.g. Boron or Mn or Cr or Molybdenum) quenched and tempered	0,28	0,50	0,025	0,025	0,003	380

^a In case of dispute, the product analysis applies.

^b Boron content can reach 0,005 %, provided non-effective boron is controlled by the addition of titanium and/or aluminium.

^c For cold forged fasteners of property classes 4.6 and 5.6, heat treatment of the wire used for cold forging or of the cold forged fastener itself may be necessary to achieve required ductility.

^d Free cutting steel is allowed for these property classes with the following maximum sulfur, phosphorus and lead contents: S: 0,34 %; P: 0,11 %; Pb: 0,35 %.

^e In case of plain carbon boron steel with a carbon content below 0,25 % (cast analysis), the minimum manganese content shall be 0,6 % for property class 8.8 and 0,7 % for property classes 9.8 and 10.9.

^f For the materials of these property classes, there shall be a sufficient hardenability to ensure a structure consisting of approximately 90 % martensite in the core of the threaded sections for the fasteners in the "as-hardened" condition before tempering.

^g This alloy steel shall contain at least one of the following elements in the minimum quantity given: chromium 0,30 %, nickel 0,30 %, molybdenum 0,20 %, vanadium 0,10 %. Where elements are specified in combinations of two, three or four and have alloy contents less than those given above, the limit value to be applied for steel class determination is 70 % of the sum of the individual limit values specified above for the two, three or four elements concerned.

^h Fasteners manufactured from phosphated raw material shall be dephosphated before heat treatment; the absence of white phosphorus enriched layer shall be detected by a suitable test method.

ⁱ Caution is advised when the use of property class 12.9/12.9 is considered. The capability of the fastener manufacturer, the service conditions and the wrenching methods should be considered. Environments can cause stress corrosion cracking of fasteners as processed as well as those coated.

7 Mechanical and physical properties

The bolts, screws and studs of the specified property classes shall, at ambient temperature²⁾, meet all the applicable mechanical and physical properties in accordance with Tables 3 to 7, regardless of which tests are performed during manufacturing or final inspection.

Clause 8 sets forth the applicability of test methods for verifying that fasteners of different types and dimensions fulfil the properties in accordance with Table 3 and Tables 4 to 7.

NOTE 1 Even if the steel properties of the fasteners meet all relevant requirements specified in Tables 2 and 3, some types of fasteners have reduced loadability due to dimensional reasons (see 8.2, 9.4 and 9.5).

NOTE 2 Although a great number of property classes are specified in this part of ISO 898, this does not mean that all classes are appropriate for all fasteners. Further guidance for application of the specific property classes is given in the relevant product standards. For non-standard fasteners, it is advisable to follow as closely as possible the choice already made for similar standard fasteners.

Table 3 — Mechanical and physical properties of bolts, screws and studs

No.	Mechanical or physical property	Property class										
		4.6	4.8	5.6	5.8	6.8	8.8		9.8	10.9	12.9/ 12.9	
							$d \leq 16 \text{ mm}^a$	$d > 16 \text{ mm}^b$	$d \leq 16 \text{ mm}$			
1	Tensile strength, R_m , MPa	nom. ^c	400		500		600	800		900	1 000	1 200
		min.	400	420	500	520	600	800	830	900	1 040	1 220
2	Lower yield strength, R_{eL}^d , MPa	nom. ^c	240	—	300	—	—	—	—	—	—	—
		min.	240	—	300	—	—	—	—	—	—	—
3	Stress at 0,2 % non-proportional elongation, $R_{p0,2}$, MPa	nom. ^c	—	—	—	—	—	640	640	720	900	1 080
		min.	—	—	—	—	—	640	660	720	940	1 100
4	Stress at 0,0048d non-proportional elongation for full-size fasteners, R_{pf} , MPa	nom. ^c	—	320	—	400	480	—	—	—	—	—
		min.	—	340 ^e	—	420 ^e	480 ^e	—	—	—	—	—
5	Stress under proof load, S_p^f , MPa	nom.	225	310	280	380	440	580	600	650	830	970
	Proof strength ratio $S_{p,nom}/R_{eL,min}$ OR $S_{p,nom}/R_{p0,2,min}$ OR $S_{p,nom}/R_{pf,min}$		0,94	0,91	0,93	0,90	0,92	0,91	0,91	0,90	0,88	0,88
6	Percentage elongation after fracture for machined test pieces, A , %	min.	22	—	20	—	—	12	12	10	9	8
7	Percentage reduction of area after fracture for machined test pieces, Z , %	min.	—				52		48	48	44	
8	Elongation after fracture for full-size fasteners, A_f (see also Annex C)	min.	—	0,24	—	0,22	0,20	—	—	—	—	—
9	Head soundness		No fracture									

2) Impact strength is tested at a temperature of $-20 \text{ }^\circ\text{C}$ (see 9.14).

Table 3 (continued)

No.	Mechanical or physical property	Property class										
		4.6	4.8	5.6	5.8	6.8	8.8		9.8	10.9	12.9/ 12.9	
							$d \leq 16 \text{ mm}^a$	$d > 16 \text{ mm}^b$	$d \leq 16 \text{ mm}$			
10	Vickers hardness, HV $F \geq 98 \text{ N}$	min.	120	130	155	160	190	250	255	290	320	385
		max.	220 ^g				250	320	335	360	380	435
11	Brinell hardness, HBW $F = 30 D^2$	min.	114	124	147	152	181	245	250	286	316	380
		max.	209 ^g				238	316	331	355	375	429
12	Rockwell hardness, HRB	min.	67	71	79	82	89	—				
		max.	95,0 ^g				99,5	—				
	Rockwell hardness, HRC	min.	—				22	23	28	32	39	
		max.	—				32	34	37	39	44	
13	Surface hardness, HV 0,3	max.	—				—			390	435	
14	Non-carburization, HV 0,3	max.	—				h			h	h	
15	Height of non-decarburized thread zone, E , mm	min.	—				$1/2 H_1$			$2/3 H_1$	$3/4 H_1$	
	Depth of complete decarburization in the thread, G , mm	max.	—				0,015					
16	Reduction of hardness after retempering, HV	max.	—				20					
17	Breaking torque, M_B , Nm	min.	—				in accordance with ISO 898-7					
18	Impact strength, K_V^{ij} , J	min.	—	27	—		27	27	27	27	k	
19	Surface integrity in accordance with	ISO 6157-1 ^l									ISO 6157-3	

- a Values do not apply to structural bolting.
- b For structural bolting $d \geq M12$.
- c Nominal values are specified only for the purpose of the designation system for property classes. See Clause 5.
- d In cases where the lower yield strength, R_{eL} , cannot be determined, it is permissible to measure the stress at 0,2 % non-proportional elongation $R_{p0,2}$.
- e For the property classes 4.8, 5.8 and 6.8, the values for $R_{pf,min}$ are under investigation. The values at the time of publication of this part of ISO 898 are given for calculation of the proof stress ratio only. They are not test values.
- f Proof loads are specified in Tables 5 and 7.
- g Hardness determined at the end of a fastener shall be 250 HV, 238 HB or 99,5 HRB maximum.
- h Surface hardness shall not be more than 30 Vickers points above the measured base metal hardness of the fastener when determination of both surface hardness and base metal hardness are carried out with HV 0,3 (see 9.11).
- i Values are determined at a test temperature of $-20 \text{ }^\circ\text{C}$ (see 9.14).
- j Applies to $d \geq 16 \text{ mm}$.
- k Value for K_V is under investigation.
- l Instead of ISO 6157-1, ISO 6157-3 may apply by agreement between the manufacturer and the purchaser.

Table 4 — Minimum ultimate tensile loads — ISO metric coarse pitch thread

Thread ^a <i>d</i>	Nominal stress area <i>A_{s,nom}</i> ^b mm ²	Property class								
		4.6	4.8	5.6	5.8	6.8	8.8	9.8	10.9	12.9/12.9
Minimum ultimate tensile load, <i>F_{m,min}</i> (<i>A_{s,nom}</i> × <i>R_{m,min}</i>), N										
M3	5,03	2 010	2 110	2 510	2 620	3 020	4 020	4 530	5 230	6 140
M3,5	6,78	2 710	2 850	3 390	3 530	4 070	5 420	6 100	7 050	8 270
M4	8,78	3 510	3 690	4 390	4 570	5 270	7 020	7 900	9 130	10 700
M5	14,2	5 680	5 960	7 100	7 380	8 520	11 350	12 800	14 800	17 300
M6	20,1	8 040	8 440	10 000	10 400	12 100	16 100	18 100	20 900	24 500
M7	28,9	11 600	12 100	14 400	15 000	17 300	23 100	26 000	30 100	35 300
M8	36,6	14 600 ^c	15 400	18 300 ^c	19 000	22 000	29 200 ^c	32 900	38 100 ^c	44 600
M10	58	23 200 ^c	24 400	29 000 ^c	30 200	34 800	46 400 ^c	52 200	60 300 ^c	70 800
M12	84,3	33 700	35 400	42 200	43 800	50 600	67 400 ^d	75 900	87 700	103 000
M14	115	46 000	48 300	57 500	59 800	69 000	92 000 ^d	104 000	120 000	140 000
M16	157	62 800	65 900	78 500	81 600	94 000	125 000 ^d	141 000	163 000	192 000
M18	192	76 800	80 600	96 000	99 800	115 000	159 000	—	200 000	234 000
M20	245	98 000	103 000	122 000	127 000	147 000	203 000	—	255 000	299 000
M22	303	121 000	127 000	152 000	158 000	182 000	252 000	—	315 000	370 000
M24	353	141 000	148 000	176 000	184 000	212 000	293 000	—	367 000	431 000
M27	459	184 000	193 000	230 000	239 000	275 000	381 000	—	477 000	560 000
M30	561	224 000	236 000	280 000	292 000	337 000	466 000	—	583 000	684 000
M33	694	278 000	292 000	347 000	361 000	416 000	576 000	—	722 000	847 000
M36	817	327 000	343 000	408 000	425 000	490 000	678 000	—	850 000	997 000
M39	976	390 000	410 000	488 000	508 000	586 000	810 000	—	1 020 000	1 200 000

^a Where no thread pitch is indicated in a thread designation, coarse pitch is specified.

^b To calculate *A_{s,nom}*, see 9.1.6.1.

^c For fasteners with thread tolerance 6az in accordance with ISO 965-4 subject to hot dip galvanizing, reduced values in accordance with ISO 10684:2004, Annex A, apply.

^d For structural bolting 70 000 N (for M12), 95 500 N (for M14) and 130 000 N (for M16).

Table 5 — Proof loads — ISO metric coarse pitch thread

Thread ^a <i>d</i>	Nominal stress area $A_{s,nom}$ ^b mm ²	Property class								
		4.6	4.8	5.6	5.8	6.8	8.8	9.8	10.9	12.9/12.9
Proof load, $F_p (A_{s,nom} \times S_{p,nom})$, N										
M3	5,03	1 130	1 560	1 410	1 910	2 210	2 920	3 270	4 180	4 880
M3,5	6,78	1 530	2 100	1 900	2 580	2 980	3 940	4 410	5 630	6 580
M4	8,78	1 980	2 720	2 460	3 340	3 860	5 100	5 710	7 290	8 520
M5	14,2	3 200	4 400	3 980	5 400	6 250	8 230	9 230	11 800	13 800
M6	20,1	4 520	6 230	5 630	7 640	8 840	11 600	13 100	16 700	19 500
M7	28,9	6 500	8 960	8 090	11 000	12 700	16 800	18 800	24 000	28 000
M8	36,6	8 240 ^c	11 400	10 200 ^c	13 900	16 100	21 200 ^c	23 800	30 400 ^c	35 500
M10	58	13 000 ^c	18 000	16 200 ^c	22 000	25 500	33 700 ^c	37 700	48 100 ^c	56 300
M12	84,3	19 000	26 100	23 600	32 000	37 100	48 900 ^d	54 800	70 000	81 800
M14	115	25 900	35 600	32 200	43 700	50 600	66 700 ^d	74 800	95 500	112 000
M16	157	35 300	48 700	44 000	59 700	69 100	91 000 ^d	102 000	130 000	152 000
M18	192	43 200	59 500	53 800	73 000	84 500	115 000	—	159 000	186 000
M20	245	55 100	76 000	68 600	93 100	108 000	147 000	—	203 000	238 000
M22	303	68 200	93 900	84 800	115 000	133 000	182 000	—	252 000	294 000
M24	353	79 400	109 000	98 800	134 000	155 000	212 000	—	293 000	342 000
M27	459	103 000	142 000	128 000	174 000	202 000	275 000	—	381 000	445 000
M30	561	126 000	174 000	157 000	213 000	247 000	337 000	—	466 000	544 000
M33	694	156 000	215 000	194 000	264 000	305 000	416 000	—	576 000	673 000
M36	817	184 000	253 000	229 000	310 000	359 000	490 000	—	678 000	792 000
M39	976	220 000	303 000	273 000	371 000	429 000	586 000	—	810 000	947 000

a Where no thread pitch is indicated in a thread designation, coarse pitch is specified.

b To calculate $A_{s,nom}$, see 9.1.6.1.

c For fasteners with thread tolerance 6az in accordance with ISO 965-4 subject to hot dip galvanizing, reduced values in accordance with ISO 10684:2004, Annex A, apply.

d For structural bolting 50 700 N (for M12), 68 800 N (for M14) and 94 500 N (for M16).

Table 6 — Minimum ultimate tensile loads — ISO metric fine pitch thread

Thread <i>d</i> × <i>P</i>	Nominal stress area $A_{s,nom}$ ^a mm ²	Property class								
		4.6	4.8	5.6	5.8	6.8	8.8	9.8	10.9	12.9/12.9
Minimum ultimate tensile load, $F_{m,min} (A_{s,nom} \times R_{m,min})$, N										
M8×1	39,2	15 700	16 500	19 600	20 400	23 500	31 360	35 300	40 800	47 800
M10×1,25	61,2	24 500	25 700	30 600	31 800	36 700	49 000	55 100	63 600	74 700
M10×1	64,5	25 800	27 100	32 300	33 500	38 700	51 600	58 100	67 100	78 700
M12×1,5	88,1	35 200	37 000	44 100	45 800	52 900	70 500	79 300	91 600	107 000
M12×1,25	92,1	36 800	38 700	46 100	47 900	55 300	73 700	82 900	95 800	112 000
M14×1,5	125	50 000	52 500	62 500	65 000	75 000	100 000	112 000	130 000	152 000
M16×1,5	167	66 800	70 100	83 500	86 800	100 000	134 000	150 000	174 000	204 000
M18×1,5	216	86 400	90 700	108 000	112 000	130 000	179 000	—	225 000	264 000
M20×1,5	272	109 000	114 000	136 000	141 000	163 000	226 000	—	283 000	332 000
M22×1,5	333	133 000	140 000	166 000	173 000	200 000	276 000	—	346 000	406 000
M24×2	384	154 000	161 000	192 000	200 000	230 000	319 000	—	399 000	469 000
M27×2	496	198 000	208 000	248 000	258 000	298 000	412 000	—	516 000	605 000
M30×2	621	248 000	261 000	310 000	323 000	373 000	515 000	—	646 000	758 000
M33×2	761	304 000	320 000	380 000	396 000	457 000	632 000	—	791 000	928 000
M36×3	865	346 000	363 000	432 000	450 000	519 000	718 000	—	900 000	1 055 000
M39×3	1 030	412 000	433 000	515 000	536 000	618 000	855 000	—	1 070 000	1 260 000

a To calculate $A_{s,nom}$, see 9.1.6.1.

Table 7 — Proof loads — ISO metric fine pitch thread

Thread <i>d</i> × <i>P</i>	Nominal stress area <i>A_{s,nom}</i> ^a mm ²	Property class								
		4.6	4.8	5.6	5.8	6.8	8.8	9.8	10.9	12.9/12.9
Proof load, <i>F_p</i> (<i>A_{s,nom}</i> × <i>S_{p,nom}</i>), N										
M8×1	39,2	8 820	12 200	11 000	14 900	17 200	22 700	25 500	32 500	38 000
M10×1,25	61,2	13 800	19 000	17 100	23 300	26 900	35 500	39 800	50 800	59 400
M10×1	64,5	14 500	20 000	18 100	24 500	28 400	37 400	41 900	53 500	62 700
M12×1,5	88,1	19 800	27 300	24 700	33 500	38 800	51 100	57 300	73 100	85 500
M12×1,25	92,1	20 700	28 600	25 800	35 000	40 500	53 400	59 900	76 400	89 300
M14×1,5	125	28 100	38 800	35 000	47 500	55 000	72 500	81 200	104 000	121 000
M16×1,5	167	37 600	51 800	46 800	63 500	73 500	96 900	109 000	139 000	162 000
M18×1,5	216	48 600	67 000	60 500	82 100	95 000	130 000	—	179 000	210 000
M20×1,5	272	61 200	84 300	76 200	103 000	120 000	163 000	—	226 000	264 000
M22×1,5	333	74 900	103 000	93 200	126 000	146 000	200 000	—	276 000	323 000
M24×2	384	86 400	119 000	108 000	146 000	169 000	230 000	—	319 000	372 000
M27×2	496	112 000	154 000	139 000	188 000	218 000	298 000	—	412 000	481 000
M30×2	621	140 000	192 000	174 000	236 000	273 000	373 000	—	515 000	602 000
M33×2	761	171 000	236 000	213 000	289 000	335 000	457 000	—	632 000	738 000
M36×3	865	195 000	268 000	242 000	329 000	381 000	519 000	—	718 000	839 000
M39×3	1 030	232 000	319 000	288 000	391 000	453 000	618 000	—	855 000	999 000

^a To calculate *A_{s,nom}*, see 9.1.6.1.

8 Applicability of test methods

8.1 General

Two main groups of test series are established for testing the mechanical and physical properties of fasteners specified in Table 3, FF and MP. Whereas group FF is used for testing finished fasteners, group MP is used for testing material properties of the fasteners. The two groups are divided into test series FF1, FF2, FF3 and FF4, and MP1 and MP2, respectively, for different types of fasteners. However, not all mechanical and physical properties specified in Table 3 can be tested on all types or sizes of fasteners due primarily to dimensional and/or loadability reasons.

8.2 Loadability of fasteners

8.2.1 Fasteners with full loadability

A fastener with full loadability is a finished fastener, standardized or non-standardized, which, when tensile tested in accordance with the test series FF1, FF2 or MP2,

a) breaks

- in the free threaded length for fasteners with $d_s > d_2$, or
- in the free threaded length or in the unthreaded shank for fasteners with $d_s \approx d_2$, and

b) meets the minimum ultimate tensile load, $F_{m,min}$, in accordance with Tables 4 or 6.

8.2.2 Fasteners which, due to their geometry, have reduced loadability

A fastener with reduced loadability is a finished fastener, standardized or non-standardized, with material properties in accordance with property classes as specified in this part of ISO 898 which, due to its geometry, does not fulfil the test requirements for loadability when tested in accordance with test series FF1, FF2 or MP2.

A fastener with reduced loadability does not normally break in the free threaded length when tensile tested in accordance with test series FF3 or FF4.

Basically, there are two geometrical reasons for reduced loadability of fasteners compared with the ultimate tensile load of the thread:

- a) a head design which applies to bolts and screws with:
 - low head with or without external driving feature,
 - low round head or low cylindrical head with internal driving feature, or
 - countersunk head with internal driving feature;
- b) a shank design which applies to fasteners which are especially designed for applications where the loadability in accordance with this part of ISO 898 is not required or even not desired, e.g. screws with waisted shank.

Test series FF3 (see Table 10) is used for the fasteners mentioned in a), above, while FF4 (see Table 11) is used for those fasteners mentioned in b).

8.3 Manufacturer's test/inspection

Fasteners produced in accordance with this part of ISO 898 shall be capable of conforming to all applicable requirements of Tables 3 to 7 when using the "feasible" tests specified in Tables 8 to 11.

This part of ISO 898 does not mandate which of the tests the manufacturer shall perform on each manufacturing lot. It is the responsibility of the manufacturer to apply suitable methods of his (or her) choice, such as in-process test or inspection, to ensure that the manufactured lot does conform to all of the applicable requirements.

In case of dispute, the test methods in accordance with Clause 9 shall apply.

8.4 Supplier's test/inspection

Suppliers may test the fasteners they provide using the methods of their choice, provided the mechanical and physical properties specified in Tables 3 to 7 are met.

In case of dispute, the test methods in accordance with Clause 9 shall apply.

8.5 Purchaser's test/inspection

The purchaser may test the delivered fasteners by the test methods given in Clause 9 using tests selected from the relevant test series given in 8.6.

In case of dispute, the test methods in accordance with Clause 9 shall apply.

8.6 Feasible tests for groups of fasteners and machined test pieces

8.6.1 General

The applicability of test series FF1 to FF4 and MP1 to MP2, using the test methods described in Clause 9, is specified in Tables 8 to 13.

Test series FF1 to FF4 in accordance with Tables 8, 9, 10 and 11 are provided for the testing of finished fasteners:

- FF1: these are tests for the determination of the properties of finished bolts and screws with full head strength and full or reduced shank (full loadability), $d_s > d_2$ or $d_s \approx d_2$ (see Table 8);
- FF2: these are tests for the determination of the properties of finished studs with full or reduced shank (full loadability), $d_s > d_2$ or $d_s \approx d_2$ (see Table 9);
- FF3: these are tests for the determination of the properties of finished bolts and screws with $d_s > d_2$ or $d_s \approx d_2$ and reduced loadability due to
 - 1) low head with or without external driving feature,
 - 2) low round head or low cylindrical head with internal driving feature, or
 - 3) countersunk head with internal driving feature(see Table 10);
- FF4: these are tests for the determination of the properties of finished bolts, screws and studs especially designed for applications where the full loadability in accordance with this part of ISO 898 is not required or not desired, e.g. fasteners with waisted shank (reduced loadability), $d_s < d_2$ (see Table 11).

Test series MP1 and MP2 in accordance with Tables 12 and 13 are provided for testing the material properties of fasteners and/or for process development. Test series FF1 to FF4 may also be used for that purpose.

- MP1: these are tests for the determination of the material properties of fasteners and/or for process development using machined test pieces (see Table 12).
- MP2: these are tests for the determination of material properties of fasteners with full loadability, $d_s \approx d_2$ or $d_s > d_2$, and/or for process development (see Table 13).

8.6.2 Applicability

The relevance of the test methods to the group of fasteners shall be in accordance with Tables 8 to 13.

8.6.3 Delivery of test results

When, for a specific order, the purchaser requires a report including test results, they shall be established using the test methods specified in Clause 9 and selected from Tables 8 to 13. Any specific test specified by the purchaser shall be agreed upon at the time of order.

Table 8 — Test series FF1 — Finished bolts and screws with full loadability

No. (see Table 3)	Property	Test method		Property class			
				4.6, 4.8, 5.6, 5.8, 6.8		8.8, 9.8, 10.9, 12.9/12.9	
				$d < 3$ mm or $l < 2,5d$ or $b < 2,0d$	$d \geq 3$ mm and $l \geq 2,5d$ and $b \geq 2,0d$	$d < 3$ mm or $l < 2,5d$ or $b < 2,0d$	$d \geq 3$ mm and $l \geq 2,5d$ and $b \geq 2,0d$
1	Minimum tensile strength, $R_{m,min}$	Tensile test under wedge loading	9.1	NF	a	NF	a
		Tensile test	9.2	NF	a	NF	a
5	Nominal stress under proof load, $S_{p,nom}$	Proof load test	9.6	NF		NF	
8	Minimum elongation after fracture, $A_{f,min}$	Tensile test for full-size fasteners	9.3	NF	bd	cd	NF
9	Head soundness	Head soundness test $1,5d \leq l < 3d$	9.8				
		$d \leq 10$ mm $l \geq 3d$					
10 or 11 or 12	Hardness	Hardness test	9.9				
13	Maximum surface hardness	Carburization test	9.11	NF	NF		
14	Non-carburization			NF	NF		
15	Maximum decarburized zone	Decarburization test	9.10	NF	NF		
16	Reduction of hardness after tempering	Retempering test	9.12	NF	NF	e	e
17	Minimum breaking torque, $M_{B,min}$	Torsional test $1,6$ mm $\leq d \leq 10$ mm, $b \geq 1d + 2p^f$	9.13	g	gh		h
19	Surface integrity	Surface discontinuity inspection	9.15				
<p>a For fasteners with $d \geq 3$ mm, $l \geq 2d$ and $b < 2d$, see 9.1.5 and 9.2.5.</p> <p>b Values for property classes 4.6, 5.6, 8.8 and 10.9 are given in Annex C.</p> <p>c For property classes 4.8, 5.8 and 6.8.</p> <p>d $l \geq 2,7d$ and $b \geq 2,2d$.</p> <p>e This test is a reference test to be applied in case of dispute.</p> <p>f For the torsional test, these specific dimensional limits apply instead of the limits specified in the header of this table.</p> <p>g For property classes 4.6 to 6.8, no values are specified in ISO 898-7.</p> <p>h May be used instead of tensile test; however, in case of dispute the tensile test applies.</p>							
<p> Feasible: the test is able to be carried out in accordance with Clause 9 and, in case of dispute, the test shall be carried out in accordance with Clause 9.</p> <p> Feasible, but carried out only when explicitly specified: the test is able to be carried out in accordance with Clause 9 as an alternative test for a given property (e.g. torsional test when tensile test is possible), or as a particular test if required in a product standard or by the purchaser at the time of the order (e.g. impact test).</p> <p> Not feasible: the test cannot be carried out either because of the form and/or dimension of the fastener (e.g. length too short to test, no head), or because it applies only to a particular category of fasteners (e.g. test for quenched and tempered fasteners).</p>							

Table 9 — Test series FF2 — Finished studs with full loadability

No. (see Table 3)	Property	Test method		Property class				
				4.6, 4.8, 5.6, 5.8, 6.8		8.8, 9.8, 10.9, 12.9/12.9		
				Subclause	$d < 3 \text{ mm}$ or $l_t < 3d$ or $b < 2,0d$	$d \geq 3 \text{ mm}$ and $l_t \geq 3d$ and $b \geq 2,0d$	$d < 3 \text{ mm}$ or $l_t < 3d$ or $b < 2,0d$	$d \geq 3 \text{ mm}$ and $l_t \geq 3d$ and $b \geq 2,0d$
1	Minimum tensile strength, $R_{m,min}$	Tensile test	9.2	NF	a	NF	a	
5	Nominal stress under proof load, $S_{p,nom}$	Proof load test	9.6	NF		NF		
8	Minimum elongation after fracture, $A_{f,min}$	Tensile test for full-size fasteners	9.3	NF	bc	bd	NF	bc
10 or 11 or 12	Hardness	Hardness test	9.9					
13	Maximum surface hardness	Carburization test	9.11	NF	NF			
14	Non-carburization			NF	NF			
15	Maximum decarburized zone	Decarburization test	9.10	NF	NF			
16	Reduction of hardness after retempering	Retempering test	9.12	NF	NF	e	e	
19	Surface integrity	Surface discontinuity inspection	9.15					

a If fracture occurs in the threaded length of the stud (metal) end, b_m , minimum hardness applies instead of $R_{m,min}$. Alternatively, the tensile strength R_m using machined test pieces in accordance with 9.7 may be determined.

b $l_t \geq 3,2d, b \geq 2,2d$.

c Values for property classes 4.6, 5.6, 8.8 and 10.9 are given in Annex C.

d For property classes 4.8, 5.8 and 6.8.

e This test is a reference test to be applied in case of dispute.



Feasible: the test is able to be carried out in accordance with Clause 9 and, in case of dispute, the test shall be carried out in accordance with Clause 9.



Feasible, but carried out only when explicitly specified: the test is able to be carried out in accordance with Clause 9 as an alternative test for a given property (e.g. torsional test when tensile test is possible), or as a particular test if required in a product standard or by the purchaser at the time of the order (e.g. impact test).



Not feasible: the test cannot be carried out either because of the form and/or dimension of the fastener (e.g. length too short to test, no head), or because it applies only to a particular category of fasteners (e.g. test for quenched and tempered fasteners).

Table 10 — Test series FF3 — Finished screws with reduced loadability due to head design

No. (see Table 3)	Property	Test method	Subclause	Property class									
				4.6, 4.8, 5.6, 5.8, 6.8		8.8, 9.8, 10.9, 12.9/12.9							
				<i>d</i> < 3 mm or <i>l</i> < 2,5 <i>d</i> or <i>b</i> < 2,0 <i>d</i>	<i>d</i> ≥ 3 mm and <i>l</i> ≥ 2,5 <i>d</i> and <i>b</i> ≥ 2,0 <i>d</i>	<i>d</i> < 3 mm or <i>l</i> < 2,5 <i>d</i> or <i>b</i> < 2,0 <i>d</i>	<i>d</i> ≥ 3 mm and <i>l</i> ≥ 2,5 <i>d</i> and <i>b</i> ≥ 2,0 <i>d</i>						
a	Minimum ultimate tensile load	Tensile test for screws which do not break in the free threaded length due to head design	9.4	NF	a	NF	a						
10 or 11 or 12	Hardness	Hardness test	9.9										
13	Maximum surface hardness	Carburization test	9.11	NF	NF								
14	Non-carburization			NF	NF								
15	Maximum decarburized zone	Decarburization test	9.10	NF	NF								
16	Reduction of hardness after retempering	Retempering test	9.12	NF	NF	b	b						
19	Surface integrity	Surface discontinuity inspection	9.15										
<p>^a See relevant product standard for minimum ultimate tensile load.</p> <p>^b This test is a reference test to be applied in case of dispute.</p>													
<table style="width: 100%; border-collapse: collapse;"> <tr> <td style="width: 10%; text-align: center; vertical-align: middle;"><div style="border: 1px solid black; width: 20px; height: 15px; margin: 0 auto;"></div></td> <td>Feasible: the test is able to be carried out in accordance with Clause 9 and, in case of dispute, shall be carried out in accordance with Clause 9.</td> </tr> <tr> <td style="text-align: center; vertical-align: middle;"><div style="background-color: #cccccc; width: 20px; height: 15px; margin: 0 auto;"></div></td> <td>Feasible, but carried out only when explicitly specified: the test is able to be carried out in accordance with Clause 9 as an alternative test for a given property (e.g. torsional test when tensile test is possible), or as a particular test if required in a product standard or by the purchaser at the time of the order (e.g. impact test).</td> </tr> <tr> <td style="text-align: center; vertical-align: middle;"><div style="border: 1px solid black; width: 20px; height: 15px; display: flex; align-items: center; justify-content: center;">NF</div></td> <td>Not feasible: the test cannot be carried out, either because of the form and/or dimension of the fastener (e.g. length too short to test, no head), or because it applies only to a particular category of fasteners (e.g. test for quenched and tempered fasteners).</td> </tr> </table>								<div style="border: 1px solid black; width: 20px; height: 15px; margin: 0 auto;"></div>	Feasible: the test is able to be carried out in accordance with Clause 9 and, in case of dispute, shall be carried out in accordance with Clause 9.	<div style="background-color: #cccccc; width: 20px; height: 15px; margin: 0 auto;"></div>	Feasible, but carried out only when explicitly specified: the test is able to be carried out in accordance with Clause 9 as an alternative test for a given property (e.g. torsional test when tensile test is possible), or as a particular test if required in a product standard or by the purchaser at the time of the order (e.g. impact test).	<div style="border: 1px solid black; width: 20px; height: 15px; display: flex; align-items: center; justify-content: center;">NF</div>	Not feasible: the test cannot be carried out, either because of the form and/or dimension of the fastener (e.g. length too short to test, no head), or because it applies only to a particular category of fasteners (e.g. test for quenched and tempered fasteners).
<div style="border: 1px solid black; width: 20px; height: 15px; margin: 0 auto;"></div>	Feasible: the test is able to be carried out in accordance with Clause 9 and, in case of dispute, shall be carried out in accordance with Clause 9.												
<div style="background-color: #cccccc; width: 20px; height: 15px; margin: 0 auto;"></div>	Feasible, but carried out only when explicitly specified: the test is able to be carried out in accordance with Clause 9 as an alternative test for a given property (e.g. torsional test when tensile test is possible), or as a particular test if required in a product standard or by the purchaser at the time of the order (e.g. impact test).												
<div style="border: 1px solid black; width: 20px; height: 15px; display: flex; align-items: center; justify-content: center;">NF</div>	Not feasible: the test cannot be carried out, either because of the form and/or dimension of the fastener (e.g. length too short to test, no head), or because it applies only to a particular category of fasteners (e.g. test for quenched and tempered fasteners).												

Table 11 — Test series FF4 — Finished bolts, screws and studs with reduced loadability due to shank design (e.g. waisted shank)

Property		Test method		Property class			
				4.6, 5.6		8.8, 9.8, 10.9, 12.9/12.9	
				<i>d</i> < 3 mm or waist length < 3 <i>d</i> _s or <i>b</i> < <i>d</i>	<i>d</i> ≥ 3 mm and waist length ≥ 3 <i>d</i> _s and <i>b</i> ≥ <i>d</i>	<i>d</i> < 3 mm or waist length < 3 <i>d</i> _s or <i>b</i> < <i>d</i>	<i>d</i> ≥ 3 mm and waist length ≥ 3 <i>d</i> _s and <i>b</i> ≥ <i>d</i>
No. (see Table 3)		Subclause					
1	Minimum tensile strength, <i>R</i> _{m,min}	Tensile test for bolts and studs with waisted shank	9.5	NF	a	NF	a
10 or 11 or 12	Hardness	Hardness test	9.9				
13	Maximum surface hardness	Carburization test	9.11	NF	NF		
14	Non-carburization			NF	NF		
15	Maximum decarburized zone	Decarburization test	9.10	NF	NF		
16	Reduction of hardness after retempering	Retempering test	9.12	NF	NF	b	b
19	Surface integrity	Surface discontinuity inspection	9.15				

a *R*_m is related to the cross-sectional area of the waisted shank, $A_{ds} = \frac{\pi}{4} d_s^2$.

b This test is a reference test to be applied in case of dispute.



	Feasible: the test is able to be carried out in accordance with Clause 9 and, in case of dispute, shall be carried out in accordance with Clause 9.
	Feasible, but carried out only when explicitly specified: the test is able to be carried out in accordance with Clause 9 as an alternative test for a given property (e.g. torsional test when tensile test is possible), or as a particular test if required in a product standard or by the purchaser at the time of the order (e.g. impact test).
	Not feasible: the test cannot be carried out, either because of the form and/or dimension of the fastener (e.g. length too short to test, no head), or because it applies only to a particular category of fasteners (e.g. test for quenched and tempered fasteners).

Table 12 — Test series MP1 — Material properties determined on machined test pieces

No. (see Table 3)	Property	Test method		Property class				
				4.6, 5.6		8.8, 9.8, 10.9, 12.9/12.9		
				$3 \leq d < 4,5$ mm and $d_0 < d_{3,min}$ and $b \geq d$ and $l \geq 6,5d^a$	$d \geq 4,5$ mm and $d_0 \geq 3$ mm and $b \geq d$ and $l \geq d + 26$ mm ^a	$3 \leq d < 4,5$ mm and $d_0 < d_{3,min}$ and $b \geq d$ and $l \geq 6,5d$ abc	$4,5 \leq d \leq 16$ mm and $d_0 \geq 3$ mm and $b \geq d$ and $l \geq d + 26$ mm ade	$d > 16$ mm and $d_0 \geq 0,75d_s$ and $b \geq d$ and $l \geq 5,5d + 8$ mm afg
1	Minimum tensile strength, $R_{m,min}$	Tensile test for machined test pieces	9.7					
2	Minimum lower yield strength, $R_{eL,min}$			h	h	NF	NF	NF
3	Minimum stress at 0,2 % non-proportional elongation, $R_{p0,2,min}$			NF ^h	NF ^h			
6	Minimum elongation after fracture, A_{min}							
7	Minimum reduction of area after fracture, Z_{min}			NF	NF			
10 or 11 or 12	Hardness	Hardness test	9.9					
13	Maximum surface hardness	Carburization test	9.11	NF	NF			
14	Non-carburization			NF	NF			
15	Maximum decarburized zone	Decarburization test	9.10	NF	NF			
18	Minimum impact strength, $K_{v,min}$	Impact test $d \geq 16$ mm and l^i or $l_t \geq 55$ mm ^j	9.14	NF	k	NF		
19	Surface integrity ^l	Surface discontinuity inspection	9.15					

a To determine the minimum total length, l_t , for studs, add $1d$ to the length formula.

b For bolts and screws $l \geq 5d$ to determine Z_{min} .

c For studs $l_t \geq 6d$ to determine Z_{min} .

d For bolts and screws $l \geq d + 20$ mm to determine Z_{min} .

e For studs $l_t \geq 2d + 20$ mm to determine Z_{min} .

f For bolts and screws $l \geq 4d + 8$ mm to determine Z_{min} .

g For studs $l_t \geq 5d + 8$ mm to determine Z_{min} .

h In cases where the lower yield strength, R_{eL} , cannot be determined, it is permissible to measure the stress at 0,2 % non-proportional elongation $R_{p0,2}$.

i The solid part of the head may be included.

j For the impact test, these specific dimensional limits apply instead of the limits specified in the header of this table.

k Only for property class 5.6.

l To be evaluated before machining.

 Feasible: the test is able to be carried out in accordance with Clause 9 and, in case of dispute, shall be carried out in accordance with Clause 9.

 Feasible, but carried out only when explicitly specified: the test is able to be carried out in accordance with Clause 9 as an alternative test for a given property (e.g. torsional test when tensile test is possible), or as a particular test if required in a product standard or by the purchaser at the time of the order (e.g. impact test).

 NF Not feasible: the test cannot be carried out, either because of the form and/or dimension of the fastener (e.g. length too short to test, no head), or because it applies only to a particular category of fasteners (e.g. test for quenched and tempered fasteners).

Table 13 — Test series MP2 — Material properties determined on finished fasteners with full loadability

No. (see Table 3)	Property	Test method		Property class		
				4.6, 5.6	4.8, 5.8, 6.8	8.8, 9.8, 10.9, 12.9/12.9
				$d \geq 3 \text{ mm}$ and $l \geq 2,7d^a$ and $b \geq 2,2d$		
1	Minimum tensile strength, $R_{m,min}$	Tensile test for finished fasteners	9.2	d	d	d
4	Minimum stress at 0,0048d non-proportional elongation, $R_{pf,min}$	Tensile test for full-size fasteners	9.3	b		c
5	Nominal stress under proof load, $S_{p,nom}$	Proof load test for finished fasteners	9.6	d	d	d
8	Minimum elongation after fracture, $A_{f,min}$	Tensile test for full-size fasteners	9.3	e		e
10 or 11 or 12	Hardness	Hardness test	9.9			
13	Maximum surface hardness	Carburization test	9.11	NF	NF	
14	Non-carburization			NF	NF	
15	Maximum decarburized zone	Decarburization test	9.10	NF	NF	
16	Reduction of hardness after retempering	Retempering test	9.12	NF	NF	f
19	Surface integrity	Surface discontinuity inspection	9.15			

- a For studs with metal end stronger than the nut end, or for fully threaded studs with $l_t \geq 3,2d$.
- b For property classes 4.6 and 5.6, the stress at 0,0048d non-proportional elongation, R_{pf} , is not specified in Table 3.
- c No values available.
- d $l \geq 2,5d$ and $b \geq 2,0d$.
- e Values for A_f are given in Annex C for information.
- f This test is a reference test to be applied in case of dispute.



Feasible: the test is able to be carried out in accordance with Clause 9 and, in case of dispute, shall be carried out in accordance with Clause 9.



Feasible, but carried out only when explicitly specified: the test is able to be carried out in accordance with Clause 9 as an alternative test for a given property (e.g. torsional test when tensile test is possible), or as a particular test if required in a product standard or by the purchaser at the time of the order (e.g. impact test).



Not feasible: the test cannot be carried out, either because of the form and/or dimension of the fastener (e.g. length too short to test, no head), or because it applies only to a particular category of fasteners (e.g. test for quenched and tempered fasteners).

9 Test methods

9.1 Tensile test under wedge loading of finished bolts and screws (excluding studs)

9.1.1 General

The purpose of this tensile test is to determine simultaneously:

- the tensile strength on finished bolts and screws, R_m ;
- the integrity of the transition section between the head and the unthreaded shank or the thread.

9.1.2 Applicability

This test applies to bolts and screws with or without flange having the following specifications:

- flat bearing surface or serrated surfaces;
- head stronger than the threaded section;
- head stronger than any unthreaded shank;
- diameter of any unthreaded shank, $d_s > d_2$ or $d_s \approx d_2$;
- nominal length, $l \geq 2,5d$;
- thread length, $b \geq 2,0d$;
- structural bolts with $b < 2d$;
- $3 \text{ mm} \leq d \leq 39 \text{ mm}$;
- all property classes.

9.1.3 Apparatus

The tensile testing machine shall be in accordance with ISO 7500-1. Tooling features altering the effect of the wedge angle, α , as specified in Figure 1 and Table 16 shall not be used.

9.1.4 Testing device

The grips, the wedge and the adaptors shall be in accordance with the following:

- hardness of 45 HRC min;
- thread tolerance class of the internally threaded adaptor in accordance with Table 14;
- hole diameter, d_h , in accordance with Table 15;
- wedge in accordance with Figure 1 and Tables 15 and 16.

Table 14 — Thread tolerance classes of internally threaded adaptors

Finish of fastener	Thread tolerance class	
	Thread tolerance class of fastener before any surface coating	Thread tolerance class of internally threaded adaptor
As processed	6h or 6g	6H
Electroplating to ISO 4042	6g or 6e or 6f	6H
Zinc flake coating to ISO 10683	6g or 6e or 6f	6H
Hot dip galvanizing to ISO 10684 in order to mate with nuts tapped to thread tolerance classes:		
— 6H	6az	6H
— 6AZ	6g or 6h	6AZ
— 6AX	6g or 6h	6AX

The testing device shall be sufficiently rigid to ensure that bending occurs in the transition section between the head and the unthreaded shank or the thread.

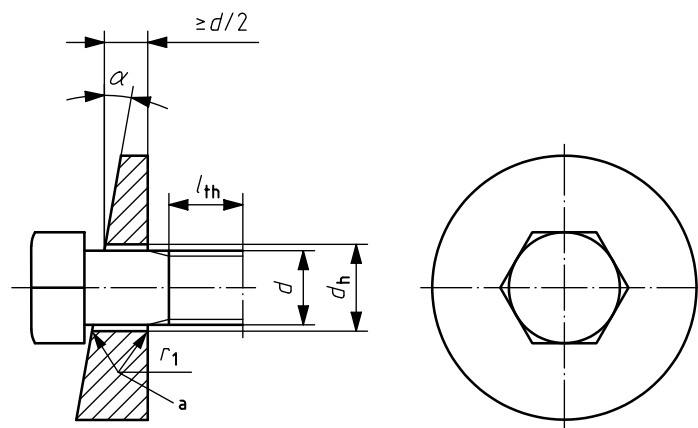

^a Radius or chamfer of 45°; see Table 15.

Figure 1 — Wedge loading of finished bolts and screws

Table 15 — Hole diameters and radius for the wedge

Dimensions in millimetres

Nominal thread diameter <i>d</i>	<i>d_h^{ab}</i>		<i>r₁^c</i>	Nominal thread diameter <i>d</i>	<i>d_h^{ab}</i>		<i>r₁^c</i>
	min.	max.			min.	max.	
3	3,4	3,58	0,7	16	17,5	17,77	1,3
3,5	3,9	4,08	0,7	18	20	20,33	1,3
4	4,5	4,68	0,7	20	22	22,33	1,6
5	5,5	5,68	0,7	22	24	24,33	1,6
6	6,6	6,82	0,7	24	26	26,33	1,6
7	7,6	7,82	0,8	27	30	30,33	1,6
8	9	9,22	0,8	30	33	33,39	1,6
10	11	11,27	0,8	33	36	36,39	1,6
12	13,5	13,77	0,8	36	39	39,39	1,6
14	15,5	15,77	1,3	39	42	42,39	1,6

a Medium series in accordance with ISO 273.

b For square neck bolts, the hole shall be adapted to accommodate the square neck.

c For product grade C, a radius, *r₁*, should be used in accordance with the following formula:

$$r_1 = r_{\max} + 0,2$$

where $r_{\max} = \frac{d_{a,\max} - d_{s,\min}}{2}$

Table 16 — Wedge angle, α , for tensile test under wedge loading

Nominal thread diameter <i>d</i>	Property class for			
	bolts and screws with unthreaded shank length <i>l_s ≥ 2d</i>		screws threaded to the head and bolts and screws with unthreaded shank length <i>l_s < 2d</i>	
	4.6, 4.8, 5.6, 5.8, 6.8, 8.8, 9.8, 10.9	12.9/ <u>12.9</u>	4.6, 4.8, 5.6, 5.8, 6.8, 8.8, 9.8, 10.9	12.9/ <u>12.9</u>
mm	$\alpha \pm 30'$			
$3 \leq d \leq 20$	10°	6°	6°	4°
$20 < d \leq 39$	6°	4°	4°	4°

For finished bolts and screws with head-bearing diameters above $1,7d$ that fail the wedge tensile test, the head may be machined to $1,7d$ and re-tested on the wedge angle specified in Table 16.

Moreover, for finished bolts and screws with head-bearing diameters above $1,9d$, the 10° wedge angle may be reduced to 6°.

9.1.5 Test procedure

The fastener shall be tested as received.

The wedge specified in 9.1.4 shall be placed under the head of the bolt or screw in accordance with Figure 1. The free threaded length, l_{th} , subjected to the load shall be a minimum of $1d$.

For structural bolts having short thread length, the tensile test under wedge loading may be performed with a free thread length, l_{th} , of less than $1d$.

The tensile test under wedge loading shall be carried out in accordance with ISO 6892-1. The speed of testing, as determined with a free-running cross-head, shall not exceed 25 mm/min.

The tensile test shall be continued until fracture occurs.

Measure the ultimate tensile load, F_m .

9.1.6 Test results

9.1.6.1 Determination of tensile strength, R_m

9.1.6.1.1 Method

The calculation of the tensile strength, R_m , is based on the nominal stress area, $A_{s,nom}$, and the ultimate tensile load, F_m , measured during the test:

$$R_m = \frac{F_m}{A_{s,nom}} \tag{1}$$

with

$$A_{s,nom} = \frac{\pi}{4} \left(\frac{d_2 + d_3}{2} \right)^2 \tag{2}$$

where

d_2 is the basic pitch diameter of external thread in accordance with ISO 724;

d_3 is the minor diameter of external thread

$$d_3 = d_1 - \frac{H}{6}$$

d_1 is the basic minor diameter of external thread in accordance with ISO 724;

H is the height of the fundamental triangle of the thread in accordance with ISO 68-1.

Values of the nominal stress area, $A_{s,nom}$, are given in Tables 4 and 6.

9.1.6.1.2 Requirements

For bolts and screws with $d_s > d_2$ and screws threaded to the head, the fracture shall occur in the free threaded length.

For fasteners with $d_s \approx d_2$, the fracture shall occur in the free threaded length or in the unthreaded shank.

R_m shall meet the requirements specified in Table 3. The minimum ultimate tensile load, $F_{m,min}$, specified in Tables 4 and 6 shall be met.

NOTE With small diameters, there is an increasing difference between the nominal stress area compared to the effective stress area. When hardness is used for process control/testing, especially for smaller diameters, it can be necessary to increase the hardness above the minimum hardness specified in Table 3 to achieve the minimum ultimate tensile load.

9.1.6.2 Determination of integrity of transition section between head and unthreaded shank/thread — Requirements

The fracture shall not occur in the head.

For bolts and screws with unthreaded shank, the fracture shall not occur in the transition section between the head and the shank.

For screws threaded to the head, the fracture that causes failure may extend or spread into the transition section between the head and the thread, or into the head, before separation, provided it originates in the free threaded length.

9.2 Tensile test for finished bolts, screws and studs for determination of tensile strength, R_m

9.2.1 General

The purpose of this tensile test is to determine the tensile strength on finished fasteners, R_m .

This test can be combined with the test specified in 9.3.

9.2.2 Applicability

This test applies to bolts, screws and studs having the following specifications:

- bolts and screws with head stronger than the threaded shank;
- bolts and screws with head stronger than any unthreaded shank;
- diameter of any unthreaded shank of $d_s > d_2$ or $d_s \approx d_2$;
- bolts and screws with nominal length $l \geq 2,5d$;
- thread length $b \geq 2,0d$;
- structural bolts with $b < 2d$;
- studs with total length $l_t \geq 3,0d$;
- $3 \text{ mm} \leq d \leq 39 \text{ mm}$;
- all property classes.

9.2.3 Apparatus

The tensile testing machine shall be in accordance with ISO 7500-1. Side thrust on the fastener shall be avoided, e.g. by self-aligning grips.

9.2.4 Testing device

The grips and the adaptors shall be as follows:

- hardness, 45 HRC min;
- hole diameter, d_h , in accordance with Table 15;
- thread tolerance class of the internally threaded adaptor(s) in accordance with Table 14.

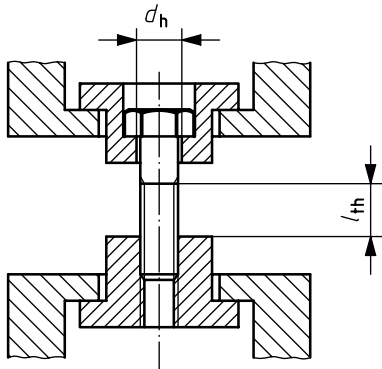

a) Example of testing device for bolts

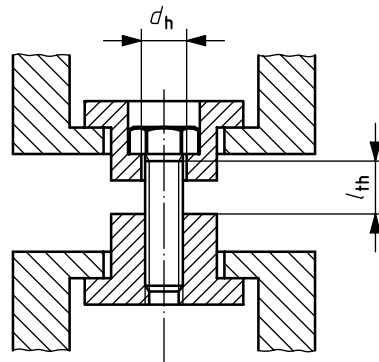

b) Example of testing device for screws

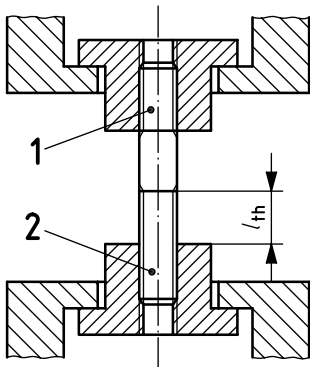

c) Example of testing device for studs

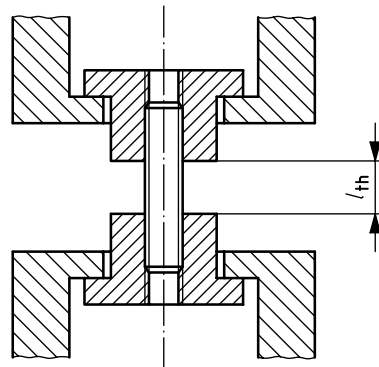

d) Example of testing device for fully threaded studs

Key

- 1 metal end
- 2 nut end
- d_h hole diameter
- l_{th} free threaded length of fastener in testing device

Figure 2 — Examples of testing devices for tensile test on full-size fasteners

9.2.5 Test procedure

The fastener shall be tested as received.

The bolt or screw to be tested shall be mounted into adaptors in accordance with Figure 2 a) or b); the stud to be tested shall be mounted into two threaded adaptors in accordance with Figure 2 c) or d). The length of thread engagement shall be at least $1d$.

The free threaded length, l_{th} , subjected to the load shall be minimum $1d$. However, when this test is combined with the test in accordance with 9.3, the free threaded length, l_{th} , subjected to the load shall be $1,2d$.

For structural bolts having short thread length, the tensile test may be performed with a free thread length l_{th} less than $1d$.

The tensile test shall be carried out in accordance with ISO 6892-1. The speed of testing, as determined with a free-running cross-head, shall not exceed 25 mm/min.

The tensile test shall be continued until fracture occurs.

Measure the ultimate tensile load, F_m .

9.2.6 Test results

9.2.6.1 Method

For calculation, see 9.1.6.1.

9.2.6.2 Requirements

For fasteners with $d_s > d_2$, the fracture shall occur in the free threaded length.

For fasteners with $d_s \approx d_2$, the fracture shall occur in the free threaded length or in the unthreaded shank.

For screws threaded to the head, the fracture which causes failure may extend or spread into the transition section between the head and the thread or into the head before separation, provided it originates in the free threaded length.

R_m shall meet the requirements specified in Table 3. The minimum ultimate tensile load, $F_{m,min}$, specified in Tables 4 and 6 shall be met.

NOTE With small diameters there is an increasing difference between the nominal compared to the effective stress area. When hardness is used for process control, especially for smaller diameters, it can be necessary to increase the hardness above the minimum hardness specified in Table 3 to achieve the minimum ultimate tensile load.

9.3 Tensile test for full-size bolts, screws and studs for determination of elongation after fracture, A_f , and stress at $0,0048d$ non-proportional elongation, R_{pf}

9.3.1 General

The purpose of this tensile test is to determine simultaneously:

- the elongation after fracture on full-size fasteners, A_f ;
- the stress at $0,0048d$ non-proportional elongation on full-size fasteners, R_{pf} .

This test can be combined with the test described in 9.2.

9.3.2 Applicability

This test applies to bolts, screws and studs having the following specifications:

- bolts and screws with head stronger than the threaded shank;
- bolts and screws with head stronger than any unthreaded shank;

- diameter of any unthreaded shank $d_s \approx d$ or $d_s > d$;
- bolts and screws with nominal length $l \geq 2,7d$;
- thread length $b \geq 2,2d$;
- studs with total length $l_t \geq 3,2d$;
- studs with metal end stronger than the nut end;
- $3 \text{ mm} \leq d \leq 39 \text{ mm}$;
- all property classes.

9.3.3 Apparatus

The tensile testing machine shall be in accordance with ISO 7500-1. Side thrust on the fastener shall be avoided, e.g. by self-aligning grips.

9.3.4 Testing device

The grips and the adaptors shall be as follows:

- hardness of 45 HRC min;
- hole diameter, d_h , in accordance with Table 15;
- thread tolerance class of the internally threaded adaptor(s) in accordance with Table 14.

The testing device shall be sufficiently rigid to avoid deformation that could influence the determination of the load at $0,0048d$ non-proportional elongation, F_{pf} , or of the elongation after fracture, A_f .

9.3.5 Test procedure

The fastener shall be tested as received.

The bolt or screw to be tested shall be mounted into adaptors in accordance with Figure 2 a) or b); the stud to be tested shall be mounted into two threaded adaptors in accordance with Figure 2 c) or d). The length of thread engagement shall be at least $1d$.

The free threaded length, l_{th} , subjected to the load shall be $1,2d$.

NOTE To obtain $l_{th} = 1,2d$ in a practical way, the following procedure is proposed: first, screw on the threaded adaptor up to the thread run-out; then unscrew the adaptor by the required number of turns corresponding to $l_{th} = 1,2d$.

The tensile test shall be carried out in accordance with ISO 6892-1. The speed of testing, as determined with a free-running cross-head, shall not exceed 10 mm/min up to the load at $0,0048d$ non-proportional elongation, F_{pf} , and 25 mm/min beyond.

The load, F , shall be measured continuously until fracture occurs, either directly by means of an adequate electronic device (e.g. microprocessor), or on the curve of load against displacement (see ISO 6892-1); the curve can be plotted either automatically or graphically.

For acceptable accurate graphical measurement, the scale of the curve shall be such that the elastic slope (straight part of the curve) lies between 30° and 45° against the load axis.

9.3.6 Test results

9.3.6.1 Determination of the elongation after fracture, A_f

9.3.6.1.1 Method

The plastic elongation, ΔL_p , is measured directly on the load-displacement curve, plotted either electronically or graphically (see Figure 3).

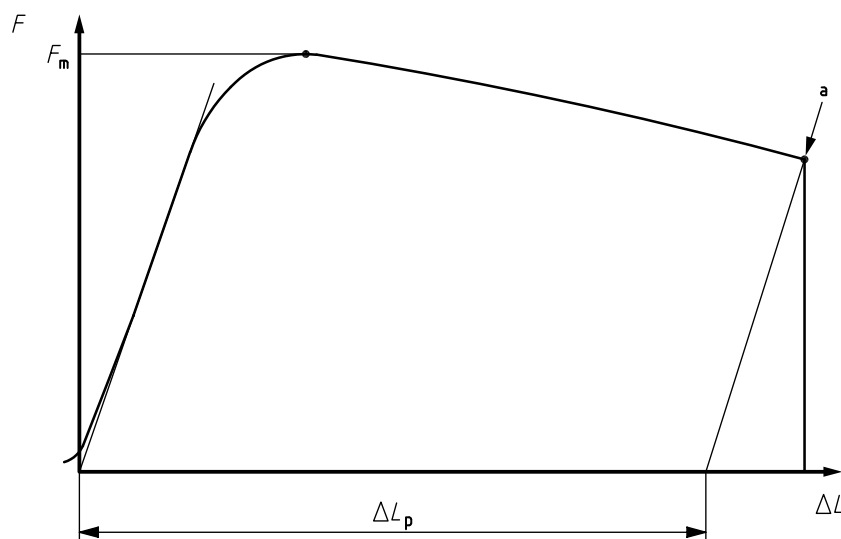

a Point of fracture.

Figure 3 — Load-displacement curve for determination of elongation after fracture, A_f

The slope of the part of the curve corresponding to the elastic range (straight part of the curve) shall be determined. A line parallel to the slope in the elastic range shall be drawn through the point of fracture, which has an intersecting point with the grip displacement axis (see Figure 3). The plastic elongation, ΔL_p , is determined on the grip displacement axis in accordance with Figure 3.

In case of doubt, the slope of the load-displacement curve in the elastic range shall be determined by drawing a line intersecting the two points of the curve corresponding to $0,4 F_p$ and $0,7 F_p$, where F_p is the proof load as specified in Tables 5 and 7.

The elongation after fracture on full-size fasteners is calculated using Formula (3):

$$A_f = \frac{\Delta L_p}{1,2d} \quad (3)$$

9.3.6.1.2 Requirements

For property classes 4.8, 5.8 and 6.8, A_f shall meet the requirement specified in Table 3.

9.3.6.2 Determination of the stress at 0,0048d non-proportional elongation, R_{pf}

9.3.6.2.1 Method

R_{pf} shall be directly determined on the load-displacement curve (see Figure 4).

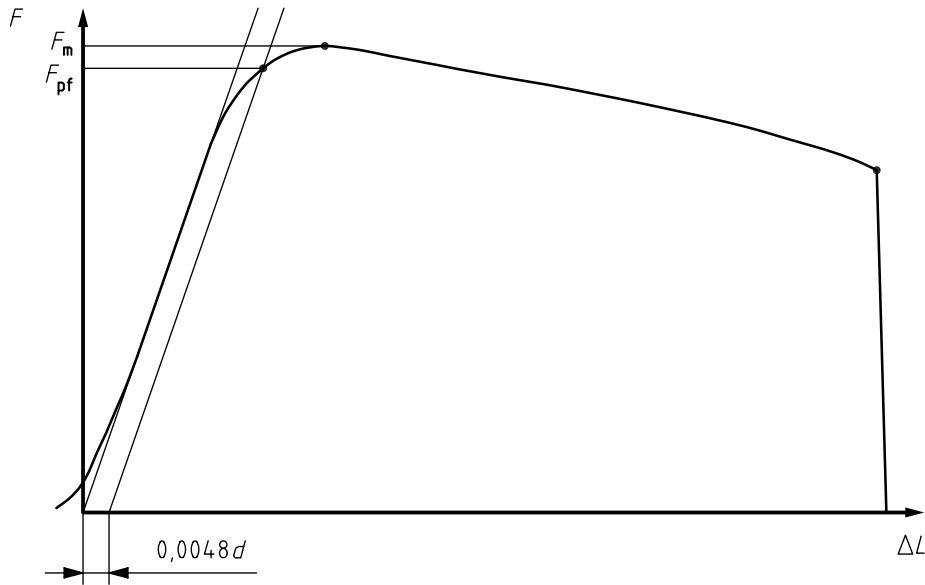

Figure 4 — Load-displacement curve for determination of stress at 0,0048d non-proportional elongation, R_{pf}

A parallel line to the slope in the elastic range (straight part of the curve) shall be drawn at a distance equal to 0,0048d on the axis of grip displacement; the intersection between this line and the curve corresponds to the load F_{pf} .

NOTE 0,0048d = 0,4 % of 1,2d.

In case of doubt, the slope of the load-elongation curve in the elastic range shall be determined by drawing a line intersecting the two points of the curve corresponding to 0,4 F_p and 0,7 F_p , where F_p is the proof load as specified in Tables 5 and 7.

The stress at 0,0048d non-proportional elongation, R_{pf} , is calculated using Formula (4):

$$R_{pf} = \frac{F_{pf}}{A_{s,nom}} \tag{4}$$

with $A_{s,nom}$ as specified in 9.1.6.1.

9.3.6.2.2 Requirements

No requirement specified.

NOTE 1 Values for R_{pf} are under investigation. See Table 3 (No. 4 and footnote e) for information.

NOTE 2 Yield strength values received from tests of full-size fasteners instead of machined test pieces can vary because of processing, test methods and size effects.

9.4 Tensile test for bolts and screws with reduced loadability due to head design

9.4.1 General

The purpose of this tensile test is to determine the tensile load for bolts and screws with reduced loadability, i.e. not expected to break in the free threaded length due to head design (see 8.2).

9.4.2 Applicability

This test applies to bolts and screws having the following specifications:

- not expected to break in the free threaded length due to head design;
- diameter of any unthreaded shank $d_s > d_2$ or $d_s \approx d_2$;
- nominal length $l \geq 2,5d$;
- thread length $b \geq 2,0d$;
- $3 \text{ mm} \leq d \leq 39 \text{ mm}$;
- all property classes.

9.4.3 Apparatus

The tensile testing machine shall be in accordance with ISO 7500-1. Side thrust on the fastener shall be avoided, e.g. by self-aligning grips.

9.4.4 Testing device

The grips and the adaptors shall be as follows:

- hardness of 45 HRC min;
- hole diameter, d_h , in accordance with Table 15;
- thread tolerance class of the internally threaded adaptor in accordance with Table 14.

9.4.5 Test procedure

The fastener shall be tested as received.

The bolt or screw to be tested shall be mounted into adaptors in accordance with Figure 2 a) or b).

The free threaded length, l_{th} , subjected to the load shall be a minimum of $1d$.

The tensile test shall be carried out in accordance with ISO 6892-1. The speed of testing, as determined with a free-running cross-head, shall not exceed 25 mm/min.

The tensile test shall be continued until fracture occurs.

The ultimate tensile load, F_m , shall be measured.

9.4.6 Test results — Requirements

The ultimate tensile load, F_m , shall be equal to or above the minimum ultimate tensile load as specified in the relevant product standard or other relevant specification.

9.5 Tensile test for fasteners with waisted shank

9.5.1 General

The purpose of this tensile test is to determine the tensile strength, R_m , for fasteners with waisted shank (see 8.2).

9.5.2 Applicability

This test applies to fasteners having the following specifications:

- diameter of unthreaded shank $d_s < d_2$;
- length of waisted shank $\geq 3d_s$ (see L_c in Figure 6);
- thread length $b \geq 1d$;
- $3 \text{ mm} \leq d \leq 39 \text{ mm}$;
- property classes 4.6, 5.6, 8.8, 9.8, 10.9 and 12.9/12.9.

9.5.3 Apparatus

The tensile testing machine shall be in accordance with ISO 7500-1. Side thrust on the fastener shall be avoided, e.g. by self-aligning grips.

9.5.4 Testing device

The grips and the adaptors shall be as follows:

- hardness of 45 HRC min;
- hole diameter, d_h , in accordance with Table 15;
- thread tolerance class of the internally threaded adaptor(s) in accordance with Table 14.

9.5.5 Test procedure

The fastener shall be tested as received.

The bolt to be tested shall be mounted into an adaptor in accordance with Figure 2 a). The stud to be tested shall be mounted into two threaded adaptors in accordance with Figure 2 c). The length of thread engagement shall be at least $1d$.

The tensile test shall be carried out in accordance with ISO 6892-1. The speed of testing, as determined with a free-running cross-head, shall not exceed 25 mm/min.

The tensile test shall be continued until fracture occurs.

The ultimate tensile load, F_m , shall be measured.

9.5.6 Test results

9.5.6.1 Method

The calculation of the tensile strength, R_m , is based on the cross-sectional area of the waisted shank, A_{ds} , and the ultimate tensile load, F_m , measured during the test:

$$R_m = \frac{F_m}{A_{ds}} \quad (5)$$

with

$$A_{ds} = \frac{\pi}{4} d_s^2$$

9.5.6.2 Requirements

The fracture shall occur in the waisted shank.

R_m shall meet the requirement specified in Table 3.

9.6 Proof load test for finished bolts, screws and studs

9.6.1 General

The proof load test consists of two main operations, as follows,

- application of a specified tensile proof load (see Figure 5), and
- measurement of permanent elongation, if any, caused by the proof load.

9.6.2 Applicability

This test applies to bolts, screws and studs having the following specifications:

- bolts and screws with head stronger than the threaded shank;
- bolts and screws with head stronger than any unthreaded shank;
- diameter of unthreaded shank $d_s > d_2$ or $d_s \approx d_2$;
- bolts and screws with nominal length $l \geq 2,5d$;
- thread length $b \geq 2,0d$;
- studs with total length $l_t \geq 3,0d$;
- $3 \text{ mm} \leq d \leq 39 \text{ mm}$;
- all property classes.

9.6.3 Apparatus

The tensile testing machine shall be in accordance with ISO 7500-1. Side thrust on the fastener shall be avoided, e.g. by self-aligning grips.

9.6.4 Testing device

The grips and the adaptors shall be in accordance with the following:

- hardness of 45 HRC min;
- hole diameter, d_h , in accordance with Table 15;
- thread tolerance class of the internally threaded adaptor(s) in accordance with Table 14.

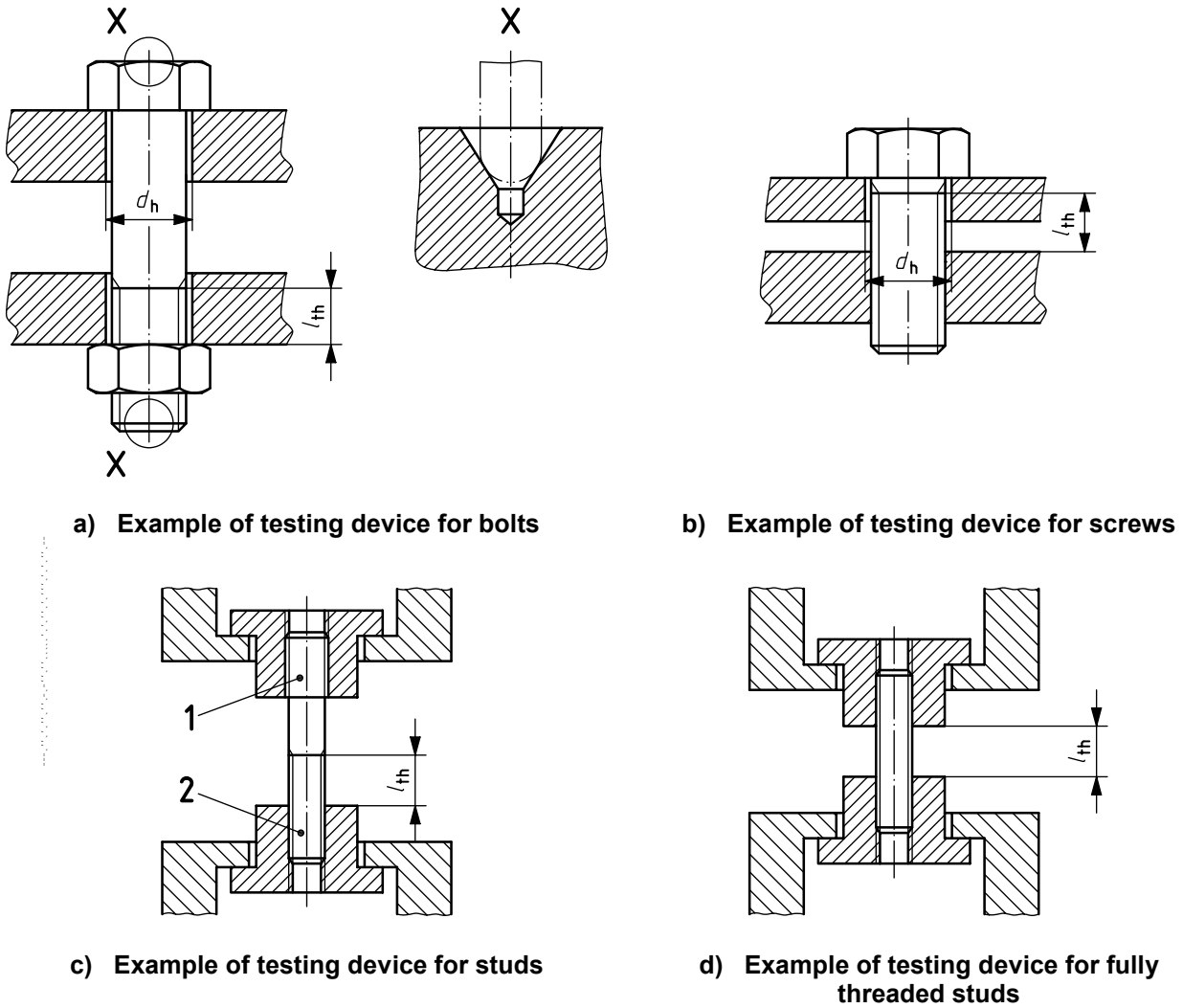

Key

- 1 metal end
- 2 nut end
- d_h hole diameter
- l_{th} free threaded length of fastener in testing device

An example is “sphere to cone” contact between the measuring points and the centre-drilled conical holes in the ends of the fastener is shown in detail X. Any other suitable method may be used.

Figure 5 — Examples of testing devices for proof load test

9.6.5 Test procedure

The fastener shall be tested as received.

The fastener shall be suitably prepared at each end, e.g. as shown in Figure 5 (see detail X). For length measurements, the fastener shall be placed in a bench-mounted measuring instrument fitted with spherical anvils or any other suitable method. Gloves or tongs shall be used to minimize measurement error caused by influence of temperature. The total length of the fastener shall be measured before loading, l_0 .

The bolt or screw to be tested shall be mounted into adaptors in accordance with Figure 5 a) or b). The stud to be tested shall be mounted into two threaded adaptors in accordance with Figure 5 c) or d). The length of thread engagement shall be at least $1d$.

The free threaded length, l_{th} , subjected to the load shall be $1d$.

NOTE To obtain $l_{th} = 1d$ in a practical way, the following procedure is proposed: first, screw on the threaded adaptor up to the thread run-out; then unscrew the adaptor by the required number of turns corresponding to $l_{th} = 1d$.

The proof load, as specified in Tables 5 and 7, shall be applied axially to the fastener.

The speed of testing, as determined with a free-running cross-head, shall not exceed 3 mm/min. The full proof load shall be held for 15 s.

After unloading, the total length of the fastener, l_1 , shall be measured.

9.6.6 Test results — Requirements

The total length of the fastener after unloading, l_1 , shall be the same as before loading, l_0 , within a tolerance of $\pm 12,5 \mu\text{m}$ allowed for uncertainty of measurement.

Some variables, such as straightness, thread alignment and uncertainty of measurement, can result in apparent elongation of the fastener when the proof load is initially applied. In such cases, the fastener shall be retested in accordance with 9.6.5 using a 3 % greater load than the proof load specified in Tables 5 and 7.

The total length after the second unloading, l_2 , shall be the same as before this loading, l_1 , within a tolerance of $\pm 12,5 \mu\text{m}$ allowed for uncertainty of measurement.

9.7 Tensile test for machined test pieces

9.7.1 General

The purpose of this tensile test is to determine

- the tensile strength, R_m ,
- the lower yield strength, R_{eL} , or stress at 0,2 % non-proportional elongation, $R_{p0,2}$,
- the percentage elongation after fracture, A , and
- the percentage reduction of area after fracture, Z .

9.7.2 Applicability

This test applies to fasteners having the following specifications:

- a) machined test pieces made from bolts and screws:
 - $3 \text{ mm} \leq d \leq 39 \text{ mm}$;
 - thread length $b \geq 1d$;
 - nominal length $l \geq 6d_0 + 2r + d$ (as specified in Figure 6) to determine A ;
 - nominal length $l \geq 4d_0 + 2r + d$ (as specified in Figure 6) to determine Z ;
- b) machined test pieces made from studs:
 - $3 \text{ mm} \leq d \leq 39 \text{ mm}$;
 - thread length $b \geq 1d$;
 - thread length of the stud metal end $b_m \geq 1d$;
 - total length $l_t \geq 6d_0 + 2r + 2d$ (as specified in Figure 6) to determine A ;
 - total length $l_t \geq 4d_0 + 2r + 2d$ (as specified in Figure 6) to determine Z ;
- c) property classes 4.6, 5.6, 8.8, 9.8, 10.9 and 12.9/12.9.

NOTE Machined test pieces can be made from fasteners which, due to their geometry, have reduced loadability, provided the head is stronger than the cross-sectional area, S_0 , of the test piece, and also from fasteners with unthreaded shank diameter $d_s < d_2$ (see 8.2).

Fasteners in property classes 4.8, 5.8 and 6.8 (work-hardened fasteners) shall be tensile tested full-size (see 9.3).

9.7.3 Apparatus

The tensile testing machine shall be in accordance with ISO 7500-1. Side thrust on the fastener shall be avoided, e.g. by self-aligning grips.

9.7.4 Testing device

The grips and the adaptors shall be as follows:

- hardness of 45 HRC min;
- hole diameter, d_h , in accordance with Table 15;
- thread tolerance class of the internally threaded adaptor(s) in accordance with Table 14.

9.7.5 Machined test pieces

The test piece shall be machined from the fastener as received. The test piece in accordance with Figure 6 shall be used for the tensile test.

The diameter of the machined test piece shall be $d_0 < d_{3,\text{min}}$, but whenever possible $d_0 \geq 3 \text{ mm}$.

When machining the test pieces of quenched and tempered fasteners with nominal diameter $d > 16$ mm the reduction of the original diameter, d , shall not exceed 25 % (about 44 % of the initial cross-sectional area). For test pieces made from studs, both ends shall have a thread length of minimum $1d$.

9.7.6 Test procedure

The tensile test shall be carried out in accordance with ISO 6892-1. The speed of testing, as determined with a free-running cross-head, shall not exceed 10 mm/min up to the load at lower yield strength, R_{eL} , or the load at the stress at 0,2 % non-proportional elongation, $R_{p0,2}$, and 25 mm/min beyond.

The tensile test shall be continued until fracture occurs.

The ultimate tensile load, F_m , shall be measured.

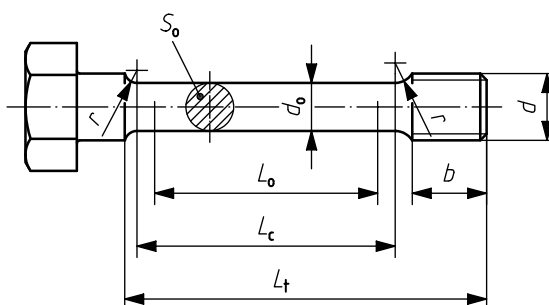

Key

- d nominal thread diameter
- d_0 diameter of machined test piece ($d_0 < d_{3,min}$ but, whenever possible, $d_0 \geq 3$ mm)
- b thread length ($b \geq d$)
- L_0 original gauge length of machined test piece
 - for determination of elongation: $L_0 = 5d_0$ or $(5,65\sqrt{S_0})$
 - for determination of reduction of area: $L_0 \geq 3d_0$
- L_c length of straight portion of machined test piece ($L_0 + d_0$)
- L_t total length of machined test piece ($L_c + 2r + b$)
- S_0 cross-sectional area of machined test piece before tensile test
- r fillet radius ($r \geq 4$ mm)

Figure 6 — Machined test piece for tensile test

9.7.7 Test results

9.7.7.1 Method

The following properties shall be determined in accordance with ISO 6892-1:

- a) tensile strength, R_m

$$R_m = \frac{F_m}{S_0}$$

- b) lower yield strength, R_{eL} , or stress at 0,2 % non-proportional elongation, $R_{p0,2}$;

(6)

c) percentage elongation after fracture, provided L_o is at least $5d_o$

$$A = \frac{L_u - L_o}{L_o} \times 100 \quad (7)$$

where L_u is the final gauge length of machined test piece (see ISO 6892-1);

d) percentage reduction of area after fracture, provided L_o is at least $3d_o$

$$Z = \frac{S_o - S_u}{S_o} \times 100 \quad (8)$$

where S_u is the cross-sectional area of machined test piece after fracture.

9.7.7.2 Requirements

The following shall meet the requirements specified in Table 3:

- minimum tensile strength, $R_{m,min}$;
- lower yield strength, R_{eL} , or stress at 0,2 % non-proportional elongation, $R_{p0,2}$;
- percentage elongation after fracture, A ;
- percentage reduction of area after fracture, Z .

9.8 Head soundness test

9.8.1 General

The purpose of the head soundness test is to check the integrity of the transition section between the head and the unthreaded shank or the thread, by striking the head of the fastener on a solid block to a given angle.

NOTE This test is generally used when the tensile test under wedge loading cannot be carried out due to the too-short length of the fastener.

9.8.2 Applicability

This test applies to bolts and screws having the following specifications:

- head stronger than the threaded shank;
- nominal length $l \geq 1,5d$;
- $d \leq 10$ mm;
- all property classes.

9.8.3 Testing device

The solid block in accordance with Figure 7 shall be as follows:

- hardness of 45 HRC min;
- hole diameter, d_h , and radius, r_1 , in accordance with Table 15;
- thickness of $2d$ minimum;

— angle, β , in accordance with Table 17.

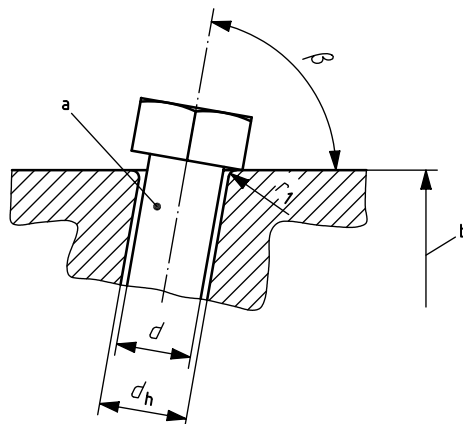

a $l \geq 1,5d$.

b Minimum thickness of solid block: $2d$.

Figure 7 — Testing device for head soundness test

Table 17 — Angle of solid block, β , for head soundness test

Property class	4.6	5.6	4.8	5.8	6.8	8.8	9.8	10.9	12.9/12.9
β	60°			80°					

9.8.4 Test procedure

The fastener shall be tested as received.

The head soundness test shall be carried out using a device in accordance with Figure 7.

The block shall be firmly fixed. A hammer shall be used to strike the head of the bolt or screw with several blows so that the head bends to an angle of $90^\circ - \beta$. Values of angle β are specified in Table 17.

The examination shall be carried out at a magnification of not less than eight times nor more than 10 times.

9.8.5 Test results — Requirements

No sign of cracking at the transition section between the head and the unthreaded shank shall be visible.

For screws threaded to the head, this requirement is fulfilled even if a crack appears in the first thread, provided the head does not fracture off.

9.9 Hardness test

9.9.1 General

The purpose of the hardness test is

- for all fasteners which cannot be tensile tested: to determine the hardness of the fastener, and
- for fasteners which can be tensile tested (see 9.1, 9.2, 9.5 and 9.7): to determine the hardness of the fastener in order to check that the maximum hardness is not exceeded.

NOTE There might not be a direct relationship between hardness and tensile strength. Maximum hardness values are specified for reasons other than theoretical maximum strength consideration (e.g. to avoid embrittlement).

Hardness may be determined either on a transverse section through the threaded portion (see 9.9.4.2) or on a suitable surface (see 9.9.4.3).

9.9.2 Applicability

This test applies to fasteners having the following specifications:

- all sizes;
- all property classes.

9.9.3 Test methods

Hardness may be determined using the Vickers, Brinell or Rockwell hardness test.

a) Vickers hardness test

The Vickers hardness test shall be carried out in accordance with ISO 6507-1.

b) Brinell hardness test

The Brinell hardness test shall be carried out in accordance with ISO 6506-1.

c) Rockwell hardness test

The Rockwell hardness test shall be carried out in accordance with ISO 6508-1.

9.9.4 Test procedure

9.9.4.1 General

Fasteners used for hardness tests shall be as received.

9.9.4.2 Hardness determined on a transverse section through the threaded portion

NOTE The term “core hardness” is commonly used for hardness determined by this test method.

A transverse section shall be taken $1d$ back from the end of the thread, and the surface shall be suitably prepared.

Hardness readings shall be performed in the area between the axis and the half-radius position (see Figure 8).

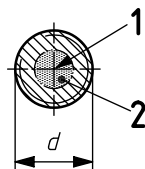

Key

- 1 axis of the fastener
- 2 half-radius area (radius of $0,25d$)

Figure 8 — Half-radius area for hardness determination

9.9.4.3 Hardness determined on a surface

The hardness shall be determined on flat surfaces of the head, on the end of the fastener or on the unthreaded shank after removal of any coating and after suitable preparation of the test specimen.

This method may be used for routine inspection.

9.9.4.4 Test load for hardness determination

The Vickers hardness test shall be carried out with a minimum load of 98 N.

The Brinell hardness test shall be carried out with a load equal to $30D^2$, expressed in newtons.

9.9.5 Requirements

For fasteners which cannot be tensile tested, and for structural bolts with short thread length which are tensile tested with free threaded length $l_{th} < 1d$, the hardness shall be within the hardness range specified in Table 3.

For fasteners which can be tensile tested with free threaded length $l_{th} \geq 1d$, and for fasteners with waisted shank and for machined test pieces, the hardness shall not exceed the values for maximum hardness in accordance with Table 3.

For fasteners of property classes 4.6, 4.8, 5.6, 5.8 and 6.8, the hardness determined in accordance with 9.9.4.3 at the end of the fastener shall not exceed the values for maximum hardness in accordance with Table 3.

For quenched and tempered fasteners, if any difference in hardness values determined in the half-radius area (see Figure 8) is greater than 30 HV, it shall be verified that the requirements of 90 % content of martensite has been achieved (see Table 2).

For work hardened fasteners of property classes 4.8, 5.8 and 6.8, hardness determined in accordance with 9.9.4.2 shall be within the hardness range specified in Table 3.

In case of dispute, the test in accordance with 9.9.4.2 using the Vickers hardness method shall be the reference test method.

9.10 Decarburization test

9.10.1 General

The purpose of the decarburization test is to detect if the surface of quenched and tempered fasteners is decarburized and to determine the depth of the completely decarburized zone (see Figure 9).

NOTE A loss of carbon content (decarburization) beyond the limits specified in Table 3 can reduce the strength of the thread and can cause failure.

Decarburization shall be determined using the following two methods:

- microscopic method (see 9.10.2);
- hardness method (see 9.10.3).

The microscopic method is used to determine the depth of the complete decarburized zone, G , and the presence of ferritic decarburization, if any, and the height of the base metal, E (see Figure 9).

The hardness method is used to determine if the requirement for the minimum height of the base metal, E , is met, and for the detection of decarburization by micro-hardness (see Figure 10).

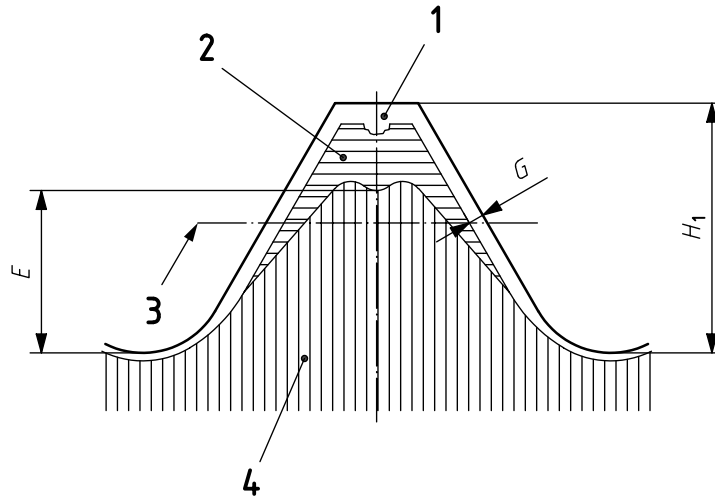

Key

- 1 complete decarburization
- 2 partial decarburization or ferritic decarburization
- 3 pitch line
- 4 base metal
- E* height of the non-decarburized thread zone
- G* depth of complete decarburization in the thread
- H₁* height of external thread in maximum material condition

Figure 9 — Decarburization zones

9.10.2 Microscopic method

9.10.2.1 Applicability

This method applies to fasteners having the following specifications:

- all sizes;
- property classes 8.8 to 12.9/12.9.

9.10.2.2 Preparation of test specimen

The test specimens shall be taken from the fasteners after all heat treatment operations have been performed and after removal of coating, if any.

The test specimens shall be taken as a longitudinal section through the thread axis, approximately one nominal diameter (*1d*) from the end of the thread. The test specimen shall be embedded in a plastic mount or, alternatively, in a clamp. After mounting, the surface shall be ground and polished in accordance with good metallographic practice.

NOTE Etching in a 3 % nital solution (concentrated nitric acid in ethanol) is usually suitable for showing changes in microstructure caused by decarburization.

9.10.2.3 Test procedure

The test specimen shall be placed under a microscope. Unless otherwise agreed, a 100× magnification shall be used for examination.

When the microscope is of a type with a ground glass screen, the extent of decarburization can be measured directly with a scale. When an eyepiece is used for measurement, it should be of an appropriate type, containing a cross-hair or scale.

9.10.2.4 Requirements

The maximum depth of complete decarburization, G (if any) shall meet the requirements specified in Table 3. The height of the non-decarburized thread zone, E , shall meet the requirements specified in Table 18, and no decarburization shall be present in the base metal (zone 4) in accordance with Figure 9.

Ferritic decarburization in zone 2 in accordance with Figure 9 should be avoided; however it shall not be cause of rejection provided the hardness requirements in accordance with 9.10.3.4 are met.

Table 18 — Values for height of external thread in maximum material condition, H_1 , and minimum height of non-decarburized zone in thread, E_{\min}

Dimensions in millimetres

Pitch of thread p^a		0,5	0,6	0,7	0,8	1	1,25	1,5	1,75	2	2,5	3	3,5	4	
H_1		0,307	0,368	0,429	0,491	0,613	0,767	0,920	1,074	1,227	1,534	1,840	2,147	2,454	
Property class	8.8, 9.8	E_{\min}^b	0,154	0,184	0,215	0,245	0,307	0,384	0,460	0,537	0,614	0,767	0,920	1,074	1,227
	10.9		0,205	0,245	0,286	0,327	0,409	0,511	0,613	0,716	0,818	1,023	1,227	1,431	1,636
	12.9/12.9		0,230	0,276	0,322	0,368	0,460	0,575	0,690	0,806	0,920	1,151	1,380	1,610	1,841
<p>^a For $P < 1,25$ mm, microscopic method only.</p> <p>^b Calculated on the basis of the specification in Table 3, No. 14.</p>															

9.10.3 Hardness method

9.10.3.1 Applicability

This method applies to fasteners having the following specifications:

- pitch $P \geq 1,25$ mm;
- property classes 8.8 to 12.9/12.9.

9.10.3.2 Preparation of test specimen

The test specimen shall be prepared in accordance with 9.10.2.2, but etching and removal of the surface coating is not necessary.

9.10.3.3 Test procedure

The Vickers hardness shall be determined at points 1 and 2 in accordance with Figure 10. The test force shall be 2,942 N (Vickers hardness test HV 0,3).

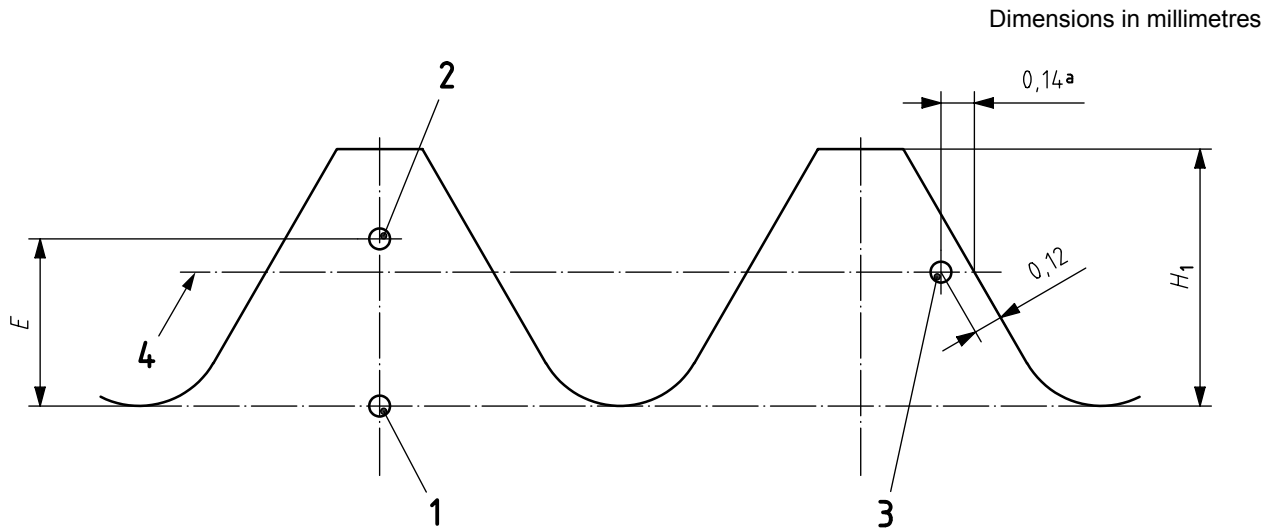

No decarburization when $HV(2) \geq HV(1) - 30$

No carburization when $HV(3) \leq HV(1) + 30$

Key

- E* height of non-decarburized zone in the thread, mm
- H_1 height of external thread in the maximum material condition, mm
- 1, 2, 3 measurement points (1 is the reference point)
- 4 pitch line

^a The value 0,14 mm is given only as an aid to locating the point along the pitch line.

Figure 10 — Hardness determination for decarburization test and carburization test

9.10.3.4 Requirements

The Vickers hardness value at point 2, $HV(2)$, shall be greater than or equal to the Vickers hardness at point 1, $HV(1)$, minus 30 Vickers units. The height of the non-decarburized zone, *E*, shall meet the requirements specified in Table 18.

NOTE Complete decarburization up to the maximum specified in Table 3 cannot be detected by the hardness measurement method.

9.11 Carburization test

9.11.1 General

The purpose of this test is to determine that the surface of a quenched and tempered fastener has not become carburized during the heat treatment. The difference between base metal hardness and surface hardness is decisive for the evaluation of the carburization condition in the surface layer.

In addition, the maximum surface hardness shall not be exceeded for property classes 10.9 and 12.9/12.9.

NOTE Carburization is detrimental as increased surface hardness can cause embrittlement or reduce fatigue resistance. Careful differentiation needs to be made between an increase in hardness caused by carburization and that due to heat treatment or cold working of the surface, such as threads rolled after heat treatment.

Carburization shall be detected by one or the other of the following two methods:

- hardness test on a longitudinal section;
- surface hardness test.

In case of dispute and when $P \geq 1,25$ mm, the hardness test on a longitudinal section in accordance with 9.11.2 shall be the reference test method.

9.11.2 Hardness test on a longitudinal section

9.11.2.1 Applicability

This method applies to fasteners having the following specifications:

- pitch $P \geq 1,25$;
- property classes 8.8 to 12.9/12.9.

9.11.2.2 Preparation of the test specimen

The test specimen shall be prepared in accordance with 9.10.2.2, but etching and removal of the coating is not necessary.

9.11.2.3 Test procedure

The Vickers hardness shall be determined at points 1 and 3 in accordance with Figure 10. The test force shall be 2,942 N (Vickers hardness test HV 0,3).

When a test specimen has been used in the test in accordance with 9.10.3.3, the hardness determination at point 3 shall be made on the pitch line of the thread adjacent to the thread on which determinations at point 1 and 2 are made.

9.11.2.4 Requirements

The Vickers hardness value at point 3, HV(3), shall be less than or equal to the value at point 1, HV(1), plus 30 Vickers units. An increase of more than 30 Vickers units indicates carburization. In addition to this requirement, the surface hardness shall not exceed 390 HV 0,3 for property class 10.9, and 435 HV 0,3 for property class 12.9/12.9 as specified in Table 3.

9.11.3 Surface hardness method

9.11.3.1 Applicability

This method applies to fasteners having the following specifications:

- all sizes;
- property classes 8.8 to 12.9/12.9.

9.11.3.2 Preparation of test specimen

A suitable flat surface on the head or end of the fastener shall be prepared by minimal grinding or polishing in order to ensure reproducible readings and maintain the original properties of the surface layer of the material.

A transverse section shall be taken $1d$ back from the end of the thread and the surface shall be suitably prepared.

9.11.3.3 Test procedure

The surface hardness shall be determined on the prepared surface in accordance with 9.9.4.3.

The base metal hardness shall be determined on the transverse section (location and preparation of the transverse section in accordance with 9.9.4.2).

The test force shall be 2,942 N (Vickers hardness test HV 0,3) for both determinations.

9.11.3.4 Requirements

The hardness value determined on the surface shall be less than or equal to the base metal hardness value plus 30 Vickers units. An increase of more than 30 Vickers units indicates carburization.

In addition to this requirement, the surface hardness shall not exceed 390 HV 0,3 for property class 10.9, and 435 HV 0,3 for property class 12.9/12.9 as specified in Table 3.

9.12 Retempering test

9.12.1 General

The purpose of this test is to check that the minimum tempering temperature has been achieved during the heat treatment process.

This test is a reference test to be applied in case of dispute.

9.12.2 Applicability

This test applies to fasteners having the following specifications:

- all sizes;
- property classes 8.8 to 12.9/12.9.

9.12.3 Test procedure

The Vickers hardness shall be determined in accordance with 9.9.4.2 by taking three readings on one fastener.

This fastener shall be retempered by holding it during 30 min at a part temperature of 10 °C less than the minimum tempering temperature as specified in Table 2. After retempering, the Vickers hardness shall be determined by taking three new readings on the same fastener and in the same area as for the first determination.

9.12.4 Requirements

The mean of the three hardness readings taken before and after retempering shall be compared. The reduction of hardness after retempering, if any, shall be less than 20 Vickers units.

9.13 Torsional test

9.13.1 General

The purpose of the torsional test is to determine the breaking torque, M_B , for bolts and screws.

9.13.2 Applicability

This test applies to fasteners having the following specifications:

- bolts and screws with head stronger than the threaded section;
- diameter of unthreaded shank $d_s \approx d_2$ or $d_s > d_2$;
- thread length $b \geq 1d + 2P$;
- $1,6 \text{ mm} \leq d \leq 10 \text{ mm}$;
- property classes 4.6 to 12.9/12.9.

NOTE For property classes 4.6 to 6.8, no values are specified in ISO 898-7.

9.13.3 Apparatus and testing device

The apparatus and testing device are specified in ISO 898-7.

9.13.4 Test procedure

The fastener shall be tested as received.

The bolt or screw shall be clamped into the test device in accordance with ISO 898-7 over a thread length of minimum $1d$. The free threaded length, l_{th} , shall be at least $2P$ at the head to thread run-out or at the unthreaded shank to thread run-out. The torque shall be applied in a continuously increasing manner.

NOTE An examination of the related basic research has indicated that the values for free threads and thread engagement length have been interchanged in ISO 898-7:1992.

9.13.5 Test results

9.13.5.1 Method

The method is specified in ISO 898-7.

9.13.5.2 Requirements

Requirements are specified in ISO 898-7.

In case of dispute, the following applies:

- for bolts and screws that cannot be tensile tested, the hardness test in accordance with 9.9 shall be the reference test;
- for bolts and screws which can be tensile tested, the tensile test shall be the reference test.

9.14 Impact test for machined test pieces

9.14.1 General

The purpose of the impact test is to check the toughness of the material of the fastener under impact load at a specified low temperature. This test is only carried out if required in a product standard or if agreed between the manufacturer and the purchaser.

9.14.2 Applicability

This test applies to fasteners having the following specifications:

- machined test pieces made from bolts, screws and studs;
- $d \geq 16$ mm;
- total length of bolts and screws (including solid part of the head) ≥ 55 mm;
- studs with total length $l_t \geq 55$ mm;
- property classes 5.6, 8.8, 9.8, 10.9 and 12.9/12.9.

9.14.3 Apparatus and testing device

The apparatus and testing device are specified in ISO 148-1.

9.14.4 Machined test piece

The test piece shall be machined from the fastener as received.

The machined test piece shall be in accordance with ISO 148-1 (Charpy V-notch test). It shall be taken lengthwise, located as close to the surface of the fastener as possible, and located in the threaded portion as far as possible. The non-notched side of the test piece shall be located near the surface of the fastener.

9.14.5 Test procedure

The machined test piece shall be maintained at a stabilized temperature of -20 °C. The impact test shall be carried out in accordance with ISO 148-1.

9.14.6 Requirements

When tested at a temperature of -20 °C, the impact strength shall be in accordance with Table 3.

NOTE Other test temperatures and impact strength values can be specified in appropriate product standards or agreed between the manufacturer and the purchaser.

9.15 Surface discontinuity inspection

Surface discontinuities shall be tested on fasteners as received.

For fasteners of property classes 4.6 to 10.9, a surface discontinuity inspection shall be carried out in accordance with ISO 6157-1. By agreement between the manufacturer and the purchaser, ISO 6157-3 may apply.

For fasteners of property class 12.9/12.9, surface discontinuity inspection shall be carried out in accordance with ISO 6157-3.

In the case of test series MP1 (see Clause 8), the surface discontinuity inspection applies before machining.

10 Marking

10.1 General

Fasteners manufactured to the requirements of this part of ISO 898 shall be designated in accordance with the designation system specified in Clause 5 and shall be marked in accordance with 10.2 and 10.3 or 10.4,

as applicable. However, the designation system specified in Clause 5 and the provisions for marking in accordance with 10.3 or 10.4 shall be used only when all relevant requirements of this part of ISO 898 are met.

Unless otherwise specified in the product standard, the height of embossed markings on the top of the head shall not be included in the head height dimensions.

10.2 Manufacturer's identification mark

A manufacturer's identification mark shall be included during the manufacturing process on all fasteners marked with a property class symbol. Manufacturer's identification marking is also recommended on fasteners not marked with a property class symbol.

A distributor who distributes fasteners that are marked with his (or her) own identification mark shall be considered to be the manufacturer.

10.3 Marking and identification of fasteners with full loadability

10.3.1 General

Fasteners with full loadability manufactured to the requirements of this part of ISO 898 shall be marked in accordance with 10.3.2 to 10.3.4.

Alternative or optional permitted marking as stated in 10.3.2 to 10.3.4 are left to the choice of the manufacturer.

10.3.2 Marking symbols for property classes

Marking symbols are specified in Table 19.

Table 19 — Marking symbols for fasteners with full loadability

Property class	4.6	4.8	5.6	5.8	6.8	8.8	9.8	10.9	12.9	<u>12.9</u>
Marking symbol^a	4.6	4.8	5.6	5.8	6.8	8.8	9.8	10.9	12.9	<u>12.9</u>
^a The dot in the marking symbol may be omitted.										

In the case of small screws, or when the shape of the head does not allow the marking in accordance with Table 19, the clock face marking symbols in accordance with Table 20 may be used.

Table 20 — Clock face system for marking bolts and screws with full loadability

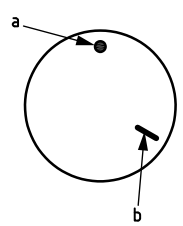
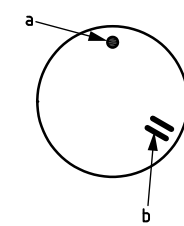
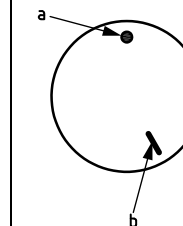
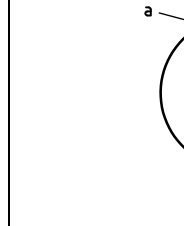
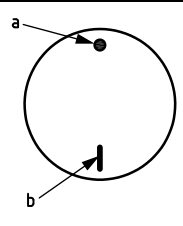
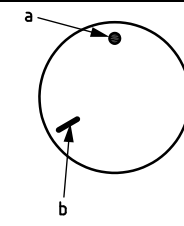
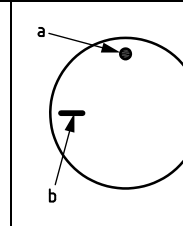
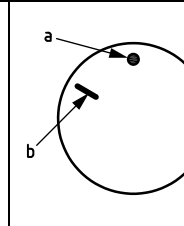
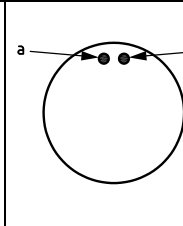
Property class	4.6	4.8	5.6	5.8	
Marking symbol					
Property class	6.8	8.8	9.8	10.9	12.9
Marking symbol					
<p>^a The twelve o'clock position (reference mark) shall be marked either by the manufacturer's identification mark or by a dot.</p> <p>^b The property class is marked by a dash or a double dash and, in the case of 12.9, by a dot.</p>					

10.3.3 Identification

10.3.3.1 Hexagon and hexalobular head bolts and screws

Hexagon and hexalobular head bolts and screws (including fasteners with flange) shall be marked with the manufacturer's identification mark and with the marking symbol of the property class specified in Table 19.

The marking is required for fasteners of all property classes and of nominal diameter $d \geq 5$ mm.

The marking shall be made preferably on the top of the head by indenting or embossing, or on the side of the head by indenting (see Figure 11). In the case of bolts or screws with flange, marking shall be on the flange when the manufacturing process does not allow marking on the top of the head.

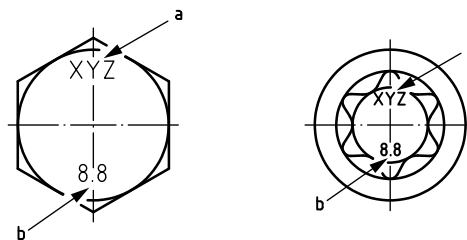

- ^a Manufacturer's identification mark.
- ^b Property class symbol.

Figure 11 — Examples of marking on hexagon and hexalobular head bolts and screws

10.3.3.2 Hexagon and hexalobular socket head cap screws

Hexagon and hexalobular socket head cap screws shall be marked with the manufacturer's identification mark and with the marking symbol of the property class specified in Table 19.

The marking is required for fasteners of all property classes and of nominal diameter $d \geq 5$ mm.

The marking shall be made preferably on the side of the head by indenting, or on the top of the head by indenting or embossing (see Figure 12).

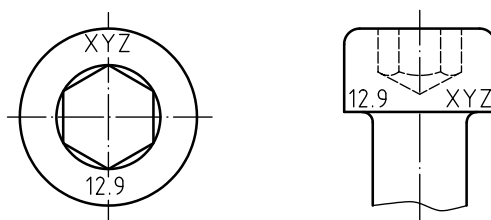

Figure 12 — Examples of marking on hexagon socket head cap screws

10.3.3.3 Cup head square neck bolts

Cup head square neck bolts shall be marked with the manufacturer's identification mark and with the marking symbol of the property class specified in Table 19.

The marking is required for fasteners of all property classes and of nominal diameter $d \geq 5$ mm.

The marking shall be made on the head by indenting or embossing (see Figure 13).

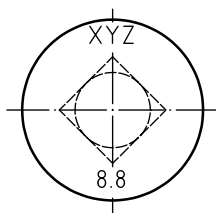

Figure 13 — Example of marking cup head square neck bolts

10.3.3.4 Studs

Studs shall be marked with the manufacturer's identification mark and with the marking symbol of the property class specified in Table 19 or the alternative marking symbol specified in Table 21.

The marking is required for studs of property classes 5.6, 8.8, 9.8, 10.9 and 12.9/12.9, and of nominal diameter $d \geq 5$ mm.

The marking shall be on the unthreaded part of the stud. If this is not possible, marking of the property class shall be on the nut end, and the manufacturer's identification mark may be omitted (see Figure 14).

For studs with interference fit, the marking of property class shall be on the nut end, and the manufacturer's identification mark may be omitted.

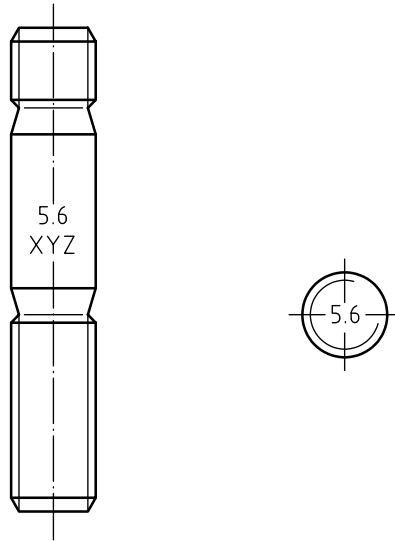

Figure 14 — Example of marking of studs

Table 21 — Alternative marking symbols for studs

Property class	5.6	8.8	9.8	10.9	12.9
Marking symbol	—	○ ^a	+	□ ^a	△ ^a
^a It is permissible to indent only the contour or the whole area of the symbol.					

10.3.3.5 Other types of bolts and screws

If required by the purchaser, the same marking systems as specified in the above subclauses of 10.3 shall be used for other types of bolts and screws and for special fasteners.

Marking is not usual for screws with flat countersunk head, oval countersunk head, cheese head, pan head or similar head shapes that are slotted, cross-recessed, or with socket or other internal driving feature.

10.3.4 Marking of bolts and screws with left-hand thread

Bolts and screws with left-hand thread and a nominal diameter of $d \geq 5$ mm shall be marked with the symbol specified in Figure 15, either on the top of the head or on the end of the fastener.

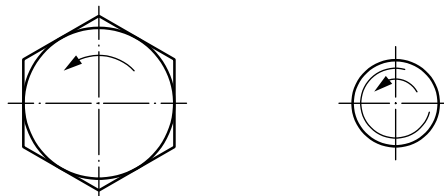
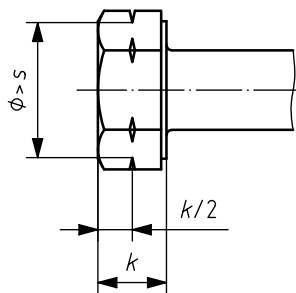

Figure 15 — Marking of bolts and screws with left-hand thread

Alternative marking for left-hand thread as specified in Figure 16 may be used for hexagon bolts and screws.

**Key**

- s width across flats
 k height of the head

Figure 16 — Alternative marking of bolts and screws with left-hand thread

10.4 Marking and identification of fasteners with reduced loadability

10.4.1 General

Fasteners with reduced loadability (see 8.2.2) manufactured to the requirements of this part of ISO 898 shall be marked in accordance with 10.3.2 and 10.3.3, except that the marking symbol for property class shall be preceded by the digit “0” in accordance with Table 22.

The marking symbols in accordance with Table 19, 20 or 21 shall not be used for fasteners with reduced loadability.

When reduced loadability applies to fasteners in accordance with a product standard, the marking symbols in accordance with Table 22 shall apply to all sizes specified in the product standard, even if some sizes would fulfil all requirements for full loadability.

10.4.2 Marking symbols for fasteners with reduced loadability

Marking symbols shall be in accordance with Table 22.

Table 22 — Marking symbols for fasteners with reduced loadability

Property class	4.6	4.8	5.6	5.8	6.8	8.8	9.8	10.9	12.9	<u>12.9</u>
Marking symbol ^a	04.6	04.8	05.6	05.8	06.8	08.8	09.8	010.9	012.9	<u>012.9</u>
^a The dot in the marking symbol may be omitted.										

10.5 Marking of packages

All packages for all types of fasteners of all sizes shall be marked (e.g. through labelling). The marking shall include the manufacturer's and/or distributor's identification and the marking symbol for property class in accordance with Table 19 or Table 22, as well as the manufacturing lot number as defined in ISO 16426.

Annex A (informative)

Relationship between tensile strength and elongation after fracture

See Table A.1.

Table A.1 — Relationship between tensile strength and elongation after fracture

Nominal tensile strength <i>R_{m,nom}</i> , MPa		400	500	600	700	800	900	1 000	1 100	1 200	1 300
Minimum elongation after fracture ^a <i>A_{f,min}</i> OR <i>A_{min}</i>	<i>A_{f,min}</i> <i>A_{min}</i>										
	0,37 22		4.6								
	0,33 20			5.6							
	0,24		4.8								
	0,22			5.8							
	0,20^b 12^c				6.8		8.8				
	— 10							9.8			
	0,13 9								10.9		
— 8										12.9/ 12.9	

^a The values for *A_{f,min}* and *A_{min}* printed in bold type are normative values (see Table 3).

^b Applies to property class 6.8 only.

^c Applies to property class 8.8 only.

Annex B (informative)

Influence of elevated temperatures on mechanical properties of fasteners

Elevated temperatures can cause changes in the mechanical properties and in the functional performance of a fastener.

Up to typical service temperatures of 150 °C, no detrimental effects due to a change of mechanical properties of fasteners are known. At temperatures over 150 °C and up to a maximum temperature of 300 °C, the functional performance of fasteners should be ensured by careful examination.

With increasing temperature, a progressive

- reduction of lower yield strength or stress at 0,2 % non-proportional elongation or stress at 0,0048*d* non-proportional elongation for finished fasteners, and
- reduction of tensile strength

can be experienced. The continuous operating of fasteners at elevated service temperatures can result in stress relaxation, which increases with higher temperatures. Stress relaxation accompanies a loss of clamp force.

Work-hardened fasteners (property classes 4.8, 5.8, 6.8) are more sensitive with regard to stress relaxation compared with quenched and tempered or stress-relieved fasteners.

Care should be taken when lead-containing steels are used for fasteners at elevated temperatures. For such fasteners, a risk of liquid metal embrittlement (LME) should be taken into consideration when the service temperature is in the range of the melting point of lead.

Information for the selection and application of steels for use at elevated temperatures is given, for example, in EN 10269 and in ASTM F2281.

Annex C (informative)

Elongation after fracture for full-size fasteners, A_f

In Table 3, minimum values for elongation after fracture for full-size bolts, screws and studs ($A_{f,min}$) are specified for the property classes 4.8, 5.8 and 6.8 only. Values for the other property classes are given in Table C.1 for information. These values are still under investigation.

Table C.1 — Elongation after fracture for full-size fasteners, A_f

Property class	4.6	5.6	8.8	9.8	10.9	12.9/12.9
$A_{f,min}$	0,37	0,33	0,20	—	0,13	—

Bibliography

- [1] ISO 1891, *Fasteners — Terminology*
- [2] ISO 16047, *Fasteners — Torque/clamp force testing*
- [3] EN 10269, *Steels and nickel alloys for fasteners with specified elevated and/or low temperature properties*
- [4] ASTM F2281, *Standard Specification for Stainless Steel and Nickel Alloy Bolts, Hex Cap Screws, and Studs, for Heat Resistance and High Temperature Applications*
- [5] ASTM A320/A320M, *Standard Specification for Alloy-Steel and Stainless Steel Bolting for Low-Temperature Service*

ICS 21.060.10

Price based on 57 pages