

INTERNATIONAL  
STANDARD

**ISO  
10683**

Second edition  
2014-05-15

---

---

**Fasteners — Non-electrolytically  
applied zinc flake coatings**

*Fixations — Revêtements non électrolytiques de zinc lamellaire*



Reference number  
ISO 10683:2014(E)

**ISO 10683:2014(E)**



**COPYRIGHT PROTECTED DOCUMENT**

© ISO 2014

All rights reserved. Unless otherwise specified, no part of this publication may be reproduced or utilized otherwise in any form or by any means, electronic or mechanical, including photocopying, or posting on the internet or an intranet, without prior written permission. Permission can be requested from either ISO at the address below or ISO's member body in the country of the requester.

ISO copyright office  
Case postale 56 • CH-1211 Geneva 20  
Tel. + 41 22 749 01 11  
Fax + 41 22 749 09 47  
E-mail [copyright@iso.org](mailto:copyright@iso.org)  
Web [www.iso.org](http://www.iso.org)

Published in Switzerland

<b>Contents</b>	<b>Page</b>
<b>Foreword</b> .....	<b>iv</b>
<b>Introduction</b> .....	<b>vi</b>
<b>1 Scope</b> .....	<b>1</b>
<b>2 Normative references</b> .....	<b>1</b>
<b>3 Terms and definitions</b> .....	<b>2</b>
<b>4 General characteristics of the coating</b> .....	<b>2</b>
4.1 Zinc flake coating systems.....	2
4.2 Composition of the systems.....	2
4.3 Mechanical and physical properties and curing.....	2
4.4 Avoidance of internal hydrogen embrittlement.....	3
4.5 Coating systems and coating processes.....	3
<b>5 Corrosion protection and testing</b> .....	<b>3</b>
5.1 General.....	3
5.2 Neutral salt spray test.....	3
5.3 Sulfur dioxide test (Kesternich test).....	4
5.4 Bulk handling, automatic processes such as feeding and/or sorting, storage and transport.....	4
<b>6 Dimensional requirements and testing</b> .....	<b>4</b>
6.1 General.....	4
6.2 Bolts, screws, studs and nuts with ISO metric threads.....	5
6.3 Other fasteners.....	6
<b>7 Mechanical and physical properties and testing</b> .....	<b>6</b>
7.1 Appearance.....	6
7.2 Corrosion resistance related to temperature.....	6
7.3 Test methods for thickness or coating weight determination.....	6
7.4 Ductility.....	7
7.5 Adhesion/cohesion.....	7
7.6 Sacrificial cathodic protection.....	7
7.7 Torque/tension relationship.....	7
7.8 Determination of hexavalent chromium.....	8
<b>8 Applicability of tests</b> .....	<b>8</b>
8.1 General.....	8
8.2 Tests mandatory for each lot.....	8
8.3 Tests for in-process control.....	8
8.4 Tests to be conducted when specified by the purchaser.....	8
<b>9 Designation</b> .....	<b>9</b>
9.1 Designation of zinc flake coating systems for the order.....	9
9.2 Designation of zinc flake coating systems for labelling.....	9
<b>10 Ordering requirements</b> .....	<b>10</b>
<b>Annex A (informative) Design aspects and assembly of coated fasteners</b> .....	<b>11</b>
<b>Annex B (informative) Coating thickness and thread clearance for ISO metric screw threads</b> .....	<b>15</b>
<b>Annex C (informative) Control of the corrosivity of the cabinet for neutral salt spray test for coated fasteners</b> .....	<b>22</b>
<b>Bibliography</b> .....	<b>30</b>

## Foreword

ISO (the International Organization for Standardization) is a worldwide federation of national standards bodies (ISO member bodies). The work of preparing International Standards is normally carried out through ISO technical committees. Each member body interested in a subject for which a technical committee has been established has the right to be represented on that committee. International organizations, governmental and non-governmental, in liaison with ISO, also take part in the work. ISO collaborates closely with the International Electrotechnical Commission (IEC) on all matters of electrotechnical standardization.

The procedures used to develop this document and those intended for its further maintenance are described in the ISO/IEC Directives, Part 1. In particular the different approval criteria needed for the different types of ISO documents should be noted. This document was drafted in accordance with the editorial rules of the ISO/IEC Directives, Part 2 (see [www.iso.org/directives](http://www.iso.org/directives)).

Attention is drawn to the possibility that some of the elements of this document may be the subject of patent rights. ISO shall not be held responsible for identifying any or all such patent rights. Details of any patent rights identified during the development of the document will be in the Introduction and/or on the ISO list of patent declarations received (see [www.iso.org/patents](http://www.iso.org/patents)).

Any trade name used in this document is information given for the convenience of users and does not constitute an endorsement.

For an explanation on the meaning of ISO specific terms and expressions related to conformity assessment, as well as information about ISO's adherence to the WTO principles in the Technical Barriers to Trade (TBT) see the following URL: Foreword - Supplementary information

The committee responsible for this document is ISO/TC 2, *Fasteners*, SC 14, *Surface coatings*.

This second edition cancels and replaces the first edition (ISO 10683:2000). The main technical changes are the following:

- wider application to all types of fasteners and all parties involved, see Introduction, [Clause 1](#), [4.1](#), [4.3](#), [Clause 7](#) and [Annex A](#);
- full description of zinc flake coating systems, see [4.1](#), [4.2](#) and [A.1.2](#);
- definitions related to coatings for fasteners moved to the new standard ISO 1891-2;
- detailed specification in relation with hexavalent chromium;
- detailed specification concerning pre-treatment in relation with internal hydrogen embrittlement, see [4.4](#);
- precedence of corrosion resistance over thickness, see [5.2](#) and [5.3](#);
- extended range of properties for coatings and related test methods (including Kesternich test, thickness and weight determination, torque/tension relationship, determination of hexavalent chromium), see [5.3](#), [7.3](#), [7.7](#), [7.8](#) and [A.2](#);
- consideration related to bulk handling, automatic processes, storage and transport, see [5.4](#) and [A.4](#);
- alternatives for gaugeability and assemblability/mountability, see [6.2.2](#);
- revised arrangement of tests to be carried out for each lot, for in-process control or when specified, see [Clause 8](#);
- revised designation for coating systems and addition of labelling, see [Clause 9](#);
- consideration related to design aspects and assembly of coated fasteners, see new [Annex A](#);

- detailed specification for coating thickness and thread clearance for ISO metric threads, moved to new [Annex B](#);
- precise control of corrosivity for the salt spray cabinet for coated fasteners, see new [Annex C](#).

## **ISO 10683:2014(E)**

### **Introduction**

The revision of ISO 10683:2000 was made in order to define the relevant requirements on zinc flake coated fasteners (coating systems with and without hexavalent chromium) for all parties involved in the fastener field, i.e. chemical suppliers, coaters, fastener manufacturers, distributors and end users. It covers all types of fasteners, i.e. fasteners with ISO metric thread, fasteners with non-ISO metric thread (including thread forming, ASME inch 60° screw thread, etc.) and non-threaded fasteners (including washers, pins, clips, etc.). It also provides basic advice for the design and use of coated fasteners in assembly.

# Fasteners — Non-electrolytically applied zinc flake coatings

## 1 Scope

This International Standard specifies requirements for non-electrolytically applied zinc flake coatings for steel fasteners. It applies to coatings:

- with or without hexavalent chromium;
- with or without top coat;
- with or without lubricant (integral lubricant and/or subsequently added lubricant).

National regulations for the restriction or prohibition of certain chemical elements should be taken into account in the countries or regions concerned.

It applies to bolts, screws, studs and nuts with ISO metric thread, to fasteners with non-ISO metric thread, and to non-threaded fasteners such as washers, pins, clips, etc.

NOTE Coatings in accordance with this International Standard are especially used for high strength fasteners ( $\geq 1\ 000$  MPa) to avoid risk of internal hydrogen embrittlement (see 4.4).

Information for design and assembly of coated fasteners is given in [Annex A](#).

This International Standard does not specify requirements for such fastener properties as weldability or paintability. It does not apply to mechanically applied zinc coatings.

## 2 Normative references

The following documents, in whole or in part, are normatively referenced in this document and are indispensable for its application. For dated references, only the edition cited applies. For undated references, the latest edition of the referenced document (including any amendments) applies.

ISO 1463, *Metallic and oxide coatings — Measurement of coating thickness — Microscopical method*

ISO 1502, *ISO general-purpose metric screw threads — Gauges and gauging*

ISO 1891-2, *Fasteners — Terminology — Part 2: Vocabulary and definitions for coatings*<sup>1)</sup>

ISO 3269, *Fasteners — Acceptance inspection*

ISO 3613:2010, *Metallic and other inorganic coatings — Chromate conversion coatings on zinc, cadmium, aluminium-zinc alloys and zinc-aluminium alloys — Test methods*

ISO 6988, *Metallic and other non organic coatings — Sulfur dioxide test with general condensation of moisture*

ISO 8991, *Designation system for fasteners*

ISO 9227:2012, *Corrosion tests in artificial atmospheres — Salt spray tests*

ISO 16047, *Fasteners — Torque/clamp force testing*

---

1) To be published.

### 3 Terms and definitions

For the purposes of this document, the terms and definitions given in ISO 1891-2 apply.

## 4 General characteristics of the coating

### 4.1 Zinc flake coating systems

Zinc flake coating systems are produced by applying a zinc flake dispersion to the surface of a steel fastener, usually with the addition of aluminium flakes, in a suitable medium. Under the influence of heat (curing), a bonding amongst flakes and also between flakes and substrate is generated, thus forming an inorganic surface coating sufficiently electrically conducting to ensure cathodic protection. The coating may or may not contain hexavalent chromium, Cr(VI).

Special techniques may be necessary to avoid excessive or insufficient coating thickness.

Special techniques may be necessary to prevent lightweight and/or flat fasteners from sticking together (e.g. washers, clips, fasteners with captive washer, flanged nuts).

An additional top coat can be applied to increase corrosion resistance and/or to achieve specific properties (e.g. torque/tension properties, chemical resistance, aspect, colour, electrical insulation/conductivity – see [A.2](#)).

### 4.2 Composition of the systems

There are four basic zinc flake coating systems as shown in [Figure 1](#).

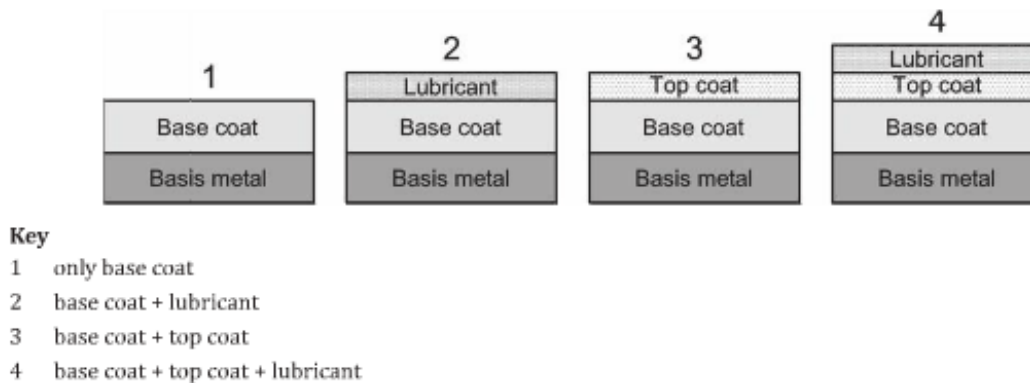

**Figure 1 — Basic zinc flake coating systems**

Base coat and top coat can be with integral lubricant, see detailed possible combinations in [A.1.2](#).

### 4.3 Mechanical and physical properties and curing

The coating process shall not adversely influence the mechanical and physical properties of the fasteners.

NOTE Distributors who coat non-coated fasteners are considered as alteration coating distributors in accordance with ISO 16426.<sup>[2]</sup>

Depending on the zinc flake coating system, the curing temperatures can be up to 320 °C. The curing temperature shall not be above the tempering temperature of quenched and tempered fasteners.

**WARNING** — The curing process (especially with higher temperature and/or longer duration) may affect the fatigue limit of fasteners with thread rolled after heat treatment. See also [A.1.3](#) for other possible effects of curing.

#### 4.4 Avoidance of internal hydrogen embrittlement

A characteristic of zinc flake coating systems is that hydrogen is not generated during the deposition process.

Pre-treatment processes using alkaline/solvent cleaner followed by mechanical cleaning do not generate hydrogen, thus eliminating all risk of internal hydrogen embrittlement (IHE).

When mechanical cleaning is not suitable for functional reasons (e.g. for fasteners with captive washers, fasteners with internal threads, fasteners to be rack coated), chemical cleaning (pickling) may be applied, provided that acid with suitable inhibitor and minimum cleaning cycle time are used to minimize the risk of internal hydrogen embrittlement. Fasteners with hardness greater than 385 HV or property class 12.9 and above shall not be subjected to acid cleaning. The duration between cleaning and coating shall be as short as possible.

A phosphating process is permitted as an alternative to mechanical cleaning (hydrogen may be generated during this pre-treatment process, however the curing process allows outward diffusion). The duration between phosphating and coating shall be as short as possible.

Cathodic cleaning processes are not permitted.

**NOTE** Zinc flake coatings have a high permeability for hydrogen which, during the curing process, allows outward diffusion of hydrogen which may have been absorbed during the pre-treatment process as specified in this subclause.

#### 4.5 Coating systems and coating processes

The type and geometry of the fasteners shall be considered when selecting a coating system and the related coating process, see [A.2](#).

### 5 Corrosion protection and testing

#### 5.1 General

Corrosion resistance in accelerated corrosion tests cannot be directly related to corrosion protection behaviour in particular service environments. However, accelerated tests are used to evaluate the corrosion resistance of the coating.

#### 5.2 Neutral salt spray test

The neutral salt spray test (NSS) in accordance with ISO 9227:2012, 5.2, is used to evaluate the corrosion resistance of the coating systems. For coated fasteners, the salt spray cabinet shall be controlled in accordance with [Annex C](#).

The neutral salt spray test shall be carried out on fasteners alone, not sooner than 24 h after coating in the "as-coated" condition, i.e. before sorting, packaging and/or assembling.

After the neutral salt spray test using test duration of [Table 1](#) there shall be no visible basis metal corrosion (red rust).

**Table 1 — Standard categories for neutral salt spray test**

Neutral salt spray test duration (without red rust)	Reference thickness of the coating system <sup>a</sup>
240 h	4 µm
480 h	5 µm
600 h	6 µm
720 h	8 µm
960 h	10 µm
<sup>a</sup> The reference thickness includes base coat(s) and top coat(s) if any, with or without Cr(VI). The corrosion resistance shall be decisive for acceptance, the reference thickness is given for guidance only. The composition of the system (base coat only, base coat + top coat, etc.) shall be specified at the time of the order.	

NOTE Guidance for the selection of coating thickness in relation to corrosion protection is given in [Annex B](#).

### 5.3 Sulfur dioxide test (Kesternich test)

This test is only intended for outdoor building fasteners.

The sulfur dioxide test with general condensation of moisture in accordance with ISO 6988 is used to evaluate the corrosion resistance of the coating systems; for outdoor building fasteners, the test shall be carried out with two litres of SO<sub>2</sub>.

The sulfur dioxide test shall be carried out on fasteners alone, no sooner than 24 h after coating in the "as-coated" condition, i.e. before sorting, packaging and/or assembling.

The minimum number of cycles shall be agreed between the supplier and the purchaser at the time of the order, i.e. 2 cycles, 3, 5, 8, 10, 12, 15 cycles, etc.

### 5.4 Bulk handling, automatic processes such as feeding and/or sorting, storage and transport

Bulk handling, automatic processes such as feeding and/or sorting, storage and transport can cause a significant reduction of corrosion protection depending on the coating system and type and geometry of the fasteners. This may especially occur for Cr(VI)-free coating systems where less self-healing effect takes place and/or where top coats are sensitive to impact damage and/or abrasion.

When necessary, an agreement should be reached between the supplier and the purchaser, e.g. by reducing the minimum duration to neutral salt spray test and/or by increasing the thickness of the coating system.

## 6 Dimensional requirements and testing

### 6.1 General

Before coating, fasteners shall be within the specified dimensions. For ISO metric threads special requirements may apply, see [6.2.2](#), [B.4](#) and [B.5](#).

## 6.2 Bolts, screws, studs and nuts with ISO metric threads

### 6.2.1 Coating thickness

When considering the coating thickness related to the desired corrosion resistance, the dispersion of the thickness of the coating system shall be taken into account, see [B.3](#).

Coating thickness has a significant influence on gaugeability, therefore thread tolerance and clearance in the thread shall be taken into account. The coating shall not cause the zero line (basic size) to be exceeded in the case of external threads; nor shall it fall below in the case of internal threads, see [B.4](#).

NOTE For standard bolts, screws, studs and nuts not specifically manufactured to accommodate zinc flake coatings, see [B.4](#) and [B.5](#).

### 6.2.2 Gaugeability and assemblability

Coated ISO metric screw threads shall be gauged in accordance with ISO 1502 with a GO-gauge of tolerance position h for external threads and H for internal threads.

When gauging a coated external thread, a maximum torque of  $0,001 d^3$  (Nm) is acceptable, where  $d$  is the nominal thread diameter in millimetres, see [Table 2](#).

**Table 2 — Maximum torque for gauging of coated ISO metric screw threads**

Nominal thread diameter, $d$ mm	Maximum torque for gauging <sup>a</sup> Nm
4	0,06
5	0,13
6	0,22
8	0,51
10	1,0
12	1,7
14	2,7
16	4,1
18	5,8
20	8,0
22	11
24	14
27	20
30	27
33	36
36	47
39	59

<sup>a</sup> For other diameters, the torque shall be calculated in accordance with  $0,001 d^3$  (Nm) and rounded to 2 digits.

Other acceptance procedures may be applied by agreement between supplier and purchaser:

- for external thread, use of a suitable nut or the original mating fastener;
- for internal thread, use of a suitable mandrel or the original mating fastener.

### 6.3 Other fasteners

There is no standard dimensional requirement for non-ISO metric threaded coated fasteners and non-threaded coated fasteners. For additional information, see [A.3](#).

## 7 Mechanical and physical properties and testing

### 7.1 Appearance

The colour of zinc flake coating is originally silver-grey. Other colours can be obtained by using a top coat. Variation in colour shall not be cause of rejection unless otherwise agreed, see [Clause 10 h](#).

The coated fastener shall be free from blisters and uncoated areas which may adversely affect the corrosion protection. Local excess of coating shall not impair functional properties (see [Clause 6](#) and [A.2](#)).

### 7.2 Corrosion resistance related to temperature

Elevated temperature can affect the corrosion protection of the coated fasteners. This test is specified for in-process control, it is not intended to check the behaviour of the coated fasteners together with the assembled parts.

After heating the coated fasteners for 3 h at 150 °C (fastener temperature) the corrosion resistance requirements as specified in [Clause 5](#) shall still be met.

Other specifications may be agreed at the time of the order.

### 7.3 Test methods for thickness or coating weight determination

Coating thickness or coating weight shall be determined using one of the following test methods:

- magnetic inductive techniques (determination of the total local thickness, on measuring areas);
- X-ray techniques (this method is only capable to determine the local thickness of the base coat, on measuring areas);
- chemical or mechanical removal of the coating system (determination of the average total coating weight of the fastener);
- microscopic method in accordance with ISO 1463 (determination of the total local thickness, on any area(s) of the fastener).

In case of dispute, the microscopic method in accordance with ISO 1463 shall be used. The thickness shall be measured on the reference areas specified in [Figure 2](#), unless otherwise agreed.

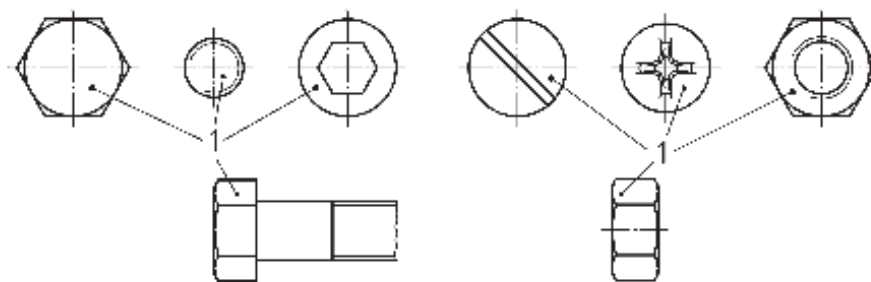

a) Reference areas for threaded fasteners

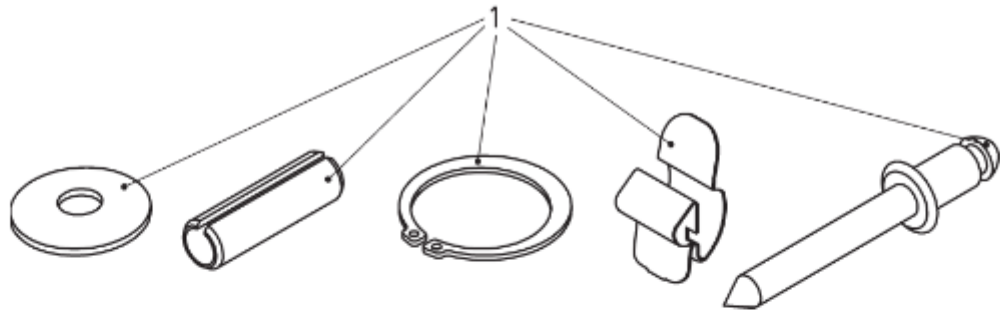

**b) Example of reference areas for non-threaded fasteners**

**Key**

1 reference area for local coating thickness determination

**Figure 2 — Reference areas for fasteners**

**7.4 Ductility**

Zinc flake coating systems are generally not very ductile, i.e. corrosion performance may be affected when deformation occurs after coating. Ductility shall be compatible with the elastic deformation occurring during assembly of the fastener, e.g. tightening of threaded fasteners, flattening for conical washers, bending for clips during installation.

The ability of the zinc flake coating system to deform should not cause impairment of the performance of the fastener, e.g. corrosion resistance, torque/tension relationship when specified. Therefore, suitable tests for particular applications shall be by agreement between the purchaser and the supplier.

NOTE Lack of ductility can generate cracks/chips of the coating thus impairing corrosion resistance.

**7.5 Adhesion/cohesion**

This test may be carried out at each step of the application process.

When an adhesive tape with 25 mm width with an adhesive strength of  $(7 \pm 1)$  N is firmly pressed by hand on to the surface and is subsequently pulled off rapidly and perpendicularly to the surface, the coating shall not be peeled off the basis metal. Small amounts of the coating material left sticking to the tape are acceptable.

NOTE Coating material visible on both surfaces of the fastener and adhesive tape usually results from lack of cohesion. Visible basis metal and coating material on the adhesive tape usually result from lack of adhesion.

**7.6 Sacrificial cathodic protection**

The sacrificial cathodic protection ability of the coating may be tested as follows:

The fastener shall be scratched down to the basis metal, using a tool with a nominal width of 0,5 mm. After a neutral salt spray test of 72 h duration in accordance with [Clause 5](#), there shall be no red rust in the scratched area.

**7.7 Torque/tension relationship**

When specified, torque/tension relationship may be determined for bolts and nuts with zinc flake coating systems including integral lubricant and/or subsequently added lubricant.

The test method shall be agreed between the supplier and the purchaser, in accordance with ISO 16047 or other relevant technical specifications.

The requirements for torque/tension relationship shall be agreed between the supplier and the purchaser. See [A.2](#) for information.

Storage conditions shall not impair the torque/tension performance of the coated fasteners (see [A.4](#)).

### **7.8 Determination of hexavalent chromium**

The presence or absence of Cr(VI) may be determined. In this case, the determination shall be done in accordance with ISO 3613:2010, 5.5.

## **8 Applicability of tests**

### **8.1 General**

All requirements specified in [Clauses 5, 6](#) and [7](#) apply as far as they are general characteristics of the coating or are separately specified by the purchaser.

### **8.2 Tests mandatory for each lot**

The following tests shall be carried out for each lot of fasteners (see ISO 3269).

- Gauging of thread (see [6.2.2](#)).
- Appearance (see [7.1](#)).

### **8.3 Tests for in-process control**

The following tests are not intended to be applied for each fastener lot, but shall be used for in-process control (see ISO 16426<sup>[9]</sup>), when relevant.

- Corrosion resistance: Neutral salt spray test (see [5.2](#)) or alternatively and only when specifically required, sulfur dioxide test (see [5.3](#)). The contact points of the fastener with a holding fixture shall not be considered in the evaluation of corrosion protection.
- Temperature resistance (see [7.2](#)).
- Coating thickness or coating weight (see [7.3](#)).
- Adhesion/cohesion (see [7.5](#)).

### **8.4 Tests to be conducted when specified by the purchaser**

The following tests are conducted when specifically required by the purchaser, see ISO 3269. In-process test results for that lot (see [8.3](#)) may be used to supply test results to the purchaser.

- Corrosion resistance: Neutral salt spray test (see [5.2](#)) or alternatively and only when specifically required, sulfur dioxide test (see [5.3](#)). The contact points of the fastener with a holding fixture shall not be considered in the evaluation of corrosion protection performance. Significant areas may be specified for the evaluation of the corrosion resistance.
- Coating thickness or coating weight (see [7.3](#)).
- Torque/tension relationship (see [7.7](#) and [Table 3](#)).
- Ductility (see [7.4](#)).
- Cathodic protection (see [7.6](#)).

- Presence or absence of Cr(VI) (see 7.8).

## 9 Designation

### 9.1 Designation of zinc flake coating systems for the order

The designation of the coating shall be added to the fastener designation in accordance with the designation system specified in ISO 8991. The zinc flake coating system shall be designated in accordance with Table 3 and in the same order. A slash (/) shall be used to separate data fields in the coating designation; a cross (x) indicates that an item has been voluntarily omitted.

**Table 3 — Designation for zinc flake coating systems for the order**

Zinc flake coating system				Neutral salt spray test duration (red rust)	Torque/tension requirement, if any
Base coat	Hexavalent chromium Cr(VI)	Organic or inorganic top coat	Additional lubricant, if any		
without integral lubricant = <b>fIZn</b> or with integral lubricant = <b>fIZnL</b>	<b>No specification:</b> may be delivered with or without Cr(VI) at the choice of the supplier or With Cr(VI) = <b>yc</b> or Without Cr(VI) = <b>nc</b>	With integral lubricant in the top coat = <b>TL</b> or Without integral lubricant in the top coat = <b>Tn</b>	<b>L</b>	e.g. 480 h	<b>C<sup>a</sup></b>
<sup>a</sup> Range of $\mu$ or $K$ values to be specified at the time of the order, see also A.2.1.					

Examples of coating designation for the order:

EXAMPLE 1 Fastener with a non-electrolytically applied zinc flake coating (fIZn), with a required minimum corrosion resistance (neutral salt spray test) of 240 h is designated as follows:

[fastener designation] - **fIZn/x/x/x/240h/x**

EXAMPLE 2 Fastener with a non-electrolytically applied zinc flake coating with integral lubricant (fIZnL), without Cr(VI) (nc), without top coat, with a required minimum corrosion resistance (neutral salt spray test) of 480 h, lubricated but without specific torque/tension requirement is designated as follows:

[fastener designation] - **fIZnL/nc/x/x/480h/x**

EXAMPLE 3 Fastener with a non-electrolytically applied zinc flake coating (fIZn) with Cr(VI) (yc), with a top coat with integral lubricant (TL), with a required minimum corrosion resistance (neutral salt spray test) of 720 h and delivered with a coefficient of friction  $\mu$  within the range of [0,10 - 0,20] (C) is designated as follows:

[fastener designation] - **fIZn/yc/TL/x/720h/C**

EXAMPLE 4 Fastener with a non-electrolytically applied zinc flake coating (fIZn) without Cr(VI) (nc), without integral lubricant, with a top coat without integral lubricant (Tn), with additional lubricant (L), with a required minimum corrosion resistance (neutral salt spray test) of 960 h, and delivered with a specified coefficient of friction  $\mu$  equal to  $0,17 \pm 0,03$  (C) is designated as follows:

[fastener designation] - **fIZn/nc/Tn/L/960h/C**

### 9.2 Designation of zinc flake coating systems for labelling

At least the following information shall be added on the label, separated by a slash (/):

- **fIZn** for the zinc flake coating (base coat) in accordance with this International Standard;

## ISO 10683:2014(E)

- **yc** for coating with Cr(VI), or **nc** for Cr(VI) free coating;
- minimum duration of corrosion resistance (neutral salt spray) in hours.

Examples for labelling:

EXAMPLE 1 Hexagon head bolt ISO 4014 – M12×80 – 10.9 – **fZn/nc/720h**

EXAMPLE 2 Hexagon nut ISO 4032 – M12 – 10 – **fZn/yc/480h**

EXAMPLE 3 Plain washer ISO 7089 – 12 – 300HV – **fZn/nc/240h**

### 10 Ordering requirements

When ordering a coating for fasteners in accordance with this International Standard, the following information shall be supplied:

- a) reference to this International Standard and the coating designation (see [Clause 9](#));
- b) the material properties of the fastener which may be influenced by the coating process, e.g. tempering temperature, hardness or other properties;
- c) torque/tension requirements, if any, including specification and related test method (e.g. ISO 16047);
- d) other requirements, if any (e.g. resistance to chemicals, suitability for adhesives, electrical conductivity/insulation);
- e) tests to be carried out, if any (see [Clause 8](#));
- f) sampling;
- g) colour if different from silver-grey;
- h) cosmetic appearance, if any.

## Annex A (informative)

### Design aspects and assembly of coated fasteners

#### A.1 Design

##### A.1.1 General

Before selecting a coating system, all functions and conditions of the assembly should be considered and not just the fastener, see A.2.2. The purchaser should consult the supplier to determine the appropriate choices for a given application.

##### A.1.2 Description of zinc flake coating systems

Figure A.1 shows typical zinc flake coating systems.

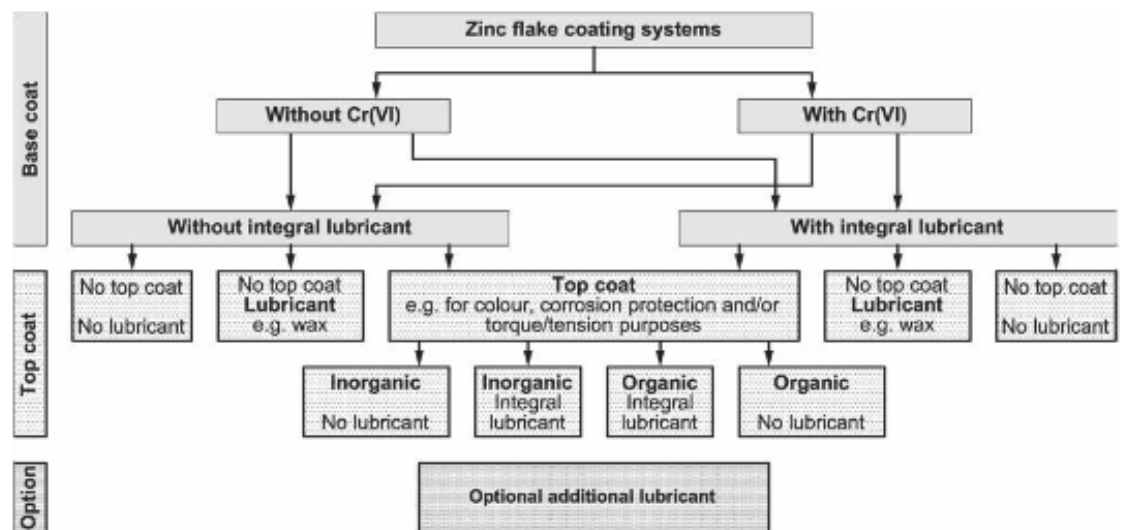

Figure A.1 — Typical zinc flake coating systems

The choice of a coating system with or without Cr(VI) should take into account national regulations.

An integral lubricant may be chosen to achieve torque/tension properties.

An additional top coat may be chosen to increase corrosion resistance and to achieve other specific properties (e.g. torque/tension properties, resistance to chemicals, mechanical resistance, aspect, colour, thermal resistance, electrical insulation/conductivity, UV resistance).

The selection of the nature of the top coat should be based on desired additional properties:

- organic top coat: electrical insulation, high resistance to chemicals or colouring possibilities, etc.
- inorganic top coat: impact/abrasion resistance or thermal resistance, etc.

An additional lubricant may be chosen to adjust torque/tension relationship.

## ISO 10683:2014(E)

### A.1.3 Coating process

Zinc flake coating systems can be applied in bulk or rack process using dip-spin or spray process.

Zinc flake coating is generally a mass process. When lots of small quantity have to be coated, a suitable coating line and/or process may be necessary in order to achieve the required properties and performances for the coated fasteners. For fasteners of large size or mass or when the risk of thread damage has to be reduced, rack instead of bulk process may be considered.

Curing process (especially with higher temperature and/or longer duration) may have an effect on the properties/performances of fasteners:

- when the curing temperature is above the tempering temperature, reduction of hardness may affect the performances of case hardened or nitrocarburised fasteners (e.g. for thread forming or self-drilling screws), or elastic and plastic deformation (e.g. for clips);
- for cold worked fasteners or fasteners with thread rolled after heat treatment, residual stresses may be reduced.

## A.2 Functional properties

### A.2.1 Assemblability and mountability

Clearance between assembly components (e.g. clearance hole), dimensional tolerances of the functional parts of the fasteners, tool gripping (e.g. for retaining rings), tool insertion (e.g. for recess and internal drives) and driving should not be impaired.

For dimensional requirements after coating for threaded fasteners, see [6.2](#) and [Annex B](#).

The compatibility of the coating system with the tightening process, especially when high speed tightening is foreseen (risk of overheating, stick/slip, etc.) should be considered.

The compatibility of the coated fasteners with the clamped parts, e.g. tapped holes, clamped parts in aluminium, magnesium, stainless steel, electrophoretically coated parts, hot dip galvanized parts, plastic, wood should be considered.

To achieve a specific clamp force and a consistent torque/clamp force relationship for fasteners with ISO metric thread, at least one of the mating threaded fasteners should be lubricated. Zinc flake coating systems provide lubricated solutions (see [A.1.2](#)). Torque/clamp force relationship can be determined in accordance with ISO 16047 and expressed as a coefficient of friction  $\mu$  (or by  $K$ -factor).

### A.2.2 Other properties of the assembly with coated fasteners

#### A.2.2.1 Chemical resistance

Organic top coats applied on zinc flake base coats are more resistant to acidic and alkaline chemicals than inorganic top coats.

#### A.2.2.2 Electrical conductivity

The electrical conductivity of zinc flake base coats with inorganic top coat is generally suitable for application of electrophoretic coatings and antistatic purposes. Zinc flake coating systems are not suitable for electrical grounding.

#### A.2.2.3 Galvanic corrosion

In order to reduce the risk of galvanic corrosion, all of the parts of the assembly should be considered (coated fasteners and clamped parts). A direct metal contact with non-coated clamped parts should be

avoided, especially e.g. for stainless steel, magnesium, copper or copper alloys. Due to their insulating effect organic top coats improve the resistance against galvanic corrosion.

The items listed in [A.2.2](#) are not exhaustive. All the specific service conditions should be considered when selecting a coating system.

#### **A.2.2.4 Cleanliness**

For cleanliness requirements, the suitability of the zinc flake coating system should be checked (e.g. dust, particle size, particle type, number of particles).

### **A.3 Particular issues related to fasteners and coating processes**

#### **A.3.1 General**

The type of fasteners should be considered when choosing a coating system and related coating process: [A.3.2](#) to [A.3.9](#) list the main issues for each type of fasteners. When 100 % sorting is required for specific characteristic(s), agreement should be reached between the supplier and the purchaser at the time of the order. Suitable measures should be taken into account for the following potential issues.

#### **A.3.2 Fasteners with ISO metric thread**

- Thread damages (the heavier the part, the more sensitive it is)
- Filling of drive/recess
- Retention of particles in threads
- For fasteners to be coated and with pitch  $P < 1$  mm, a special agreement between supplier and purchaser should be reached.
- Contamination with foreign parts

#### **A.3.3 Fasteners with captive washers**

- Retention of particles (e.g. when shot blasting is used)
- Free rotation of the washer
- Contamination with foreign parts

#### **A.3.4 Fasteners with adhesive or patch**

Applicability on zinc flake coating systems and functional properties should be evaluated.

#### **A.3.5 Nuts**

- Retention of particles in threads
- For fasteners to be coated and with pitch  $P < 1$  mm, a special agreement between supplier and purchaser should be reached.
- Contamination with foreign parts

#### **A.3.6 Prevailing torque type nuts**

For all metal prevailing torque type nuts, zinc flake coating systems in combination with silicate based top coat may cause scratching of the coating, fouling or even galling during tightening. In this case, an alternative top coat or additional lubricant should be used.



## Annex B (informative)

### Coating thickness and thread clearance for ISO metric screw threads

#### B.1 General

Dimensional requirements and testing for fasteners with ISO metric screw thread are specified in [6.2](#).

Zinc flake coating processes usually do not produce a uniform distribution of the coating thickness on the whole surface of the fasteners. As coating thickness has a significant influence on gaugeability, it is necessary to consider thread tolerance and clearance in the thread.

When designing fasteners to be coated for corrosion resistance purpose, at least the following should be taken into consideration:

- type and size of the fastener;
- tolerance class of the thread;
- typical dispersion of the thickness from the coating process (see [B.3](#));
- clearance available in the thread (see [B.4](#)).

Examples are given in [B.6](#) to explain how these aspects could be considered.

#### B.2 Geometrical relationship between coating thickness and pitch diameter

When a coating thickness  $t$  is considered in order to achieve a specified corrosion resistance (see [Clause 5](#)), the pitch diameter  $d_2$  increases by  $4t$  as illustrated in [Figure B.1](#), see [Table B.1](#).

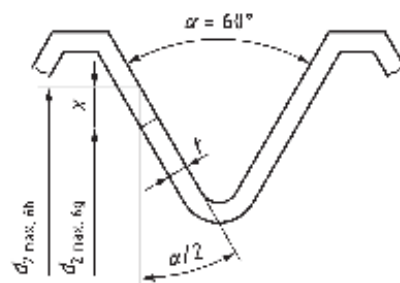

$$\frac{t}{x} = \sin 30^\circ = 0,5$$

$$\Rightarrow x = 2t \quad (1)$$

$$d_{2 \max, 6g} + 2x = d_{2 \max, 6h} \quad (2)$$

with (1) in (2)

$$d_{2 \max, 6g} + 4t = d_{2 \max, 6h}$$

$$\Rightarrow t = \frac{d_{2 \max, 6h} - d_{2 \max, 6g}}{4} \quad (3)$$

Figure B.1 — Geometrical relationship between coating thickness and pitch diameter

Table B.1 — Geometrical relationship between coating thickness and pitch diameter

Dimensions in micrometres

Coating thickness $t$	Pitch diameter increase $4 t^a$
3	12
4	16
5	20
6	24
8	32
10	40
12	48

<sup>a</sup> This pitch diameter increase corresponds to the fundamental deviation (clearance) which is needed for the coating thickness  $t$ .

### B.3 Variability of coating thickness

Zinc flake coatings for fasteners are typically applied by the dip spin process, which results in non-uniform coating thickness.

The dip spin coating process can generate significant variation in local thickness, exceeding the coating thickness  $t$  by as much as one third to half of the coating thickness. This variability of coating thickness does not typically impair thread fit. The effect of coating thickness on the pitch diameter should be carefully considered in order to achieve thread fit and gaugeability. Excessive thickness at the thread root (see [Figure B.2](#)) does not typically impair thread fit and gaugeability, and the zinc flake coating process does not typically result in excessive thickness at the thread crest.

NOTE Large diameters, long or heavy fasteners are usually rack coated.

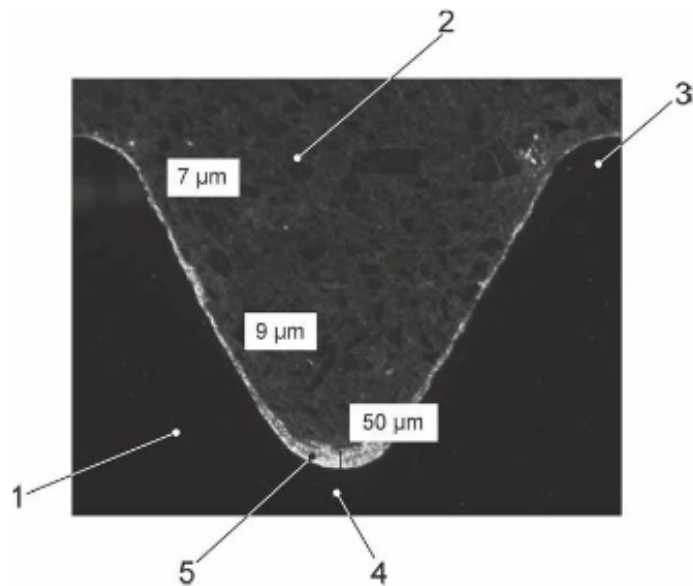
**Key**

- 1 bolt
- 2 resin
- 3 thread crest
- 4 thread root
- 5 coating

**Figure B.2 — Example of typical variation of coating thickness on a bolt thread (M12 × 1,5) resulting from a dip spin coating process**

#### B.4 Clearance for coating thickness

Fasteners should be manufactured to provide for sufficient clearance at the pitch diameter in order to accommodate the coating thickness.

Coating thickness which can be applied on ISO metric threads in accordance with ISO 965-1,<sup>[1]</sup> ISO 965-2<sup>[2]</sup> or ISO 965-3<sup>[3]</sup> depends on the fundamental deviation at the pitch diameter as given in [Table B.2](#), which itself depends on the screw thread and the following tolerance positions:

- g, f, e for external threads;
- G for internal threads.

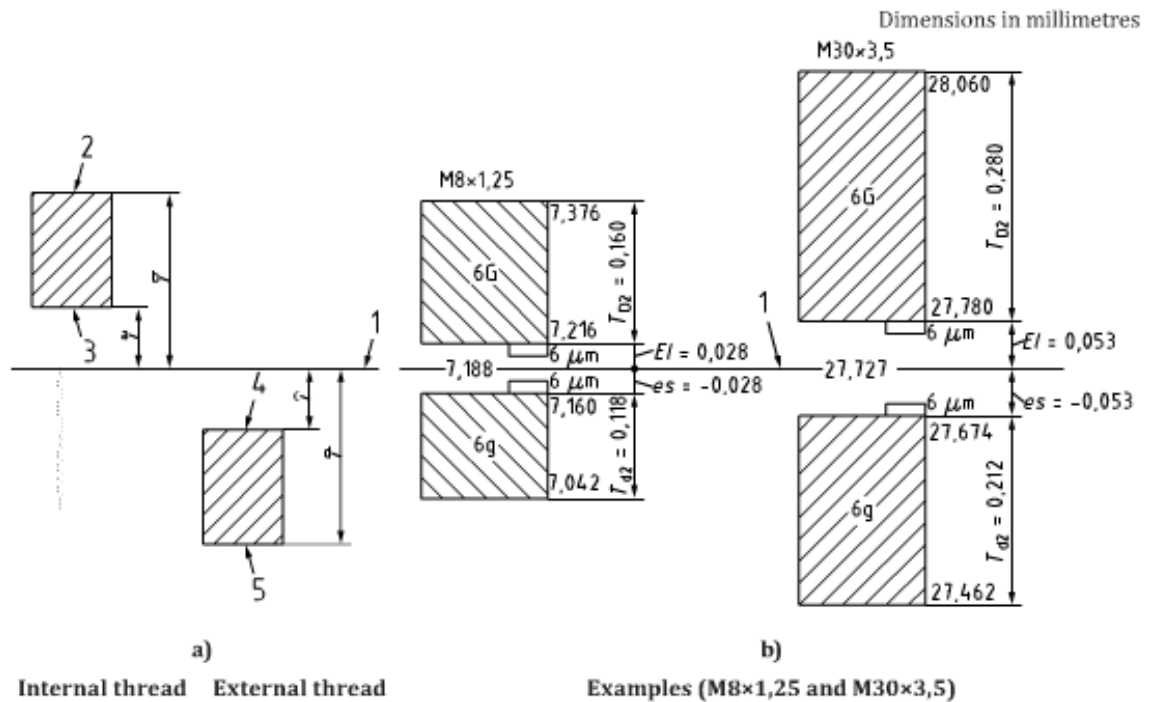

**Key**

- 1 zero line
- 2 maximum pitch diameter of the nut thread before coating
- 3 minimum pitch diameter of the nut thread before coating
- 4 maximum pitch diameter of the bolt thread before coating
- 5 minimum pitch diameter of the bolt thread before coating
- a, c The minimum clearance corresponds to the fundamental deviation.
- b, d The maximum clearance corresponds to the absolute value of the fundamental deviation plus the tolerance grade value.

**Figure B.3 — Pitch diameter tolerance position and clearance for coating**

[Table B.2](#) indicates the clearance at the pitch diameter, in function of the thread tolerance grade value of the non-coated fasteners, for a given thread pitch dimension. The minimum and maximum clearances are theoretical values limiting the range of available space for coating. They are given in order to check that the thickness of the coating system is in the given range.

Table B.2 — Theoretical limits of clearance for ISO metric threads

Thread pitch <i>P</i> mm	Nominal thread diameter <sup>a</sup> <i>d</i>		Internal thread	External thread			
	Coarse pitch mm	Fine pitch mm	Tolerance position <b>G</b>	Tolerance position <b>g</b>	Tolerance position <b>f</b>	Tolerance position <b>e</b>	
			Minimum clearance <sup>b</sup> µm	Minimum clearance <sup>b</sup> µm	Minimum clearance <sup>b</sup> µm	Minimum clearance <sup>b</sup> µm	Maximum clearance <sup>c</sup> µm
0,25	1 and 1,2	—	+ 18	- 18	—	—	—
0,3	1,4	—	+ 18	- 18	—	—	—
0,35	1,5 and 1,8	—	+ 19	- 19	- 34	—	—
0,4	2	—	+ 19	- 19	- 34	—	—
0,45	2,2 and 2,5	—	+ 20	- 20	- 35	—	—
0,5	3	—	+ 20	- 20	- 36	- 50	- 125
0,6	3,5	—	+ 21	- 21	- 36	- 53	- 138
0,7	4	—	+ 22	- 22	- 38	- 56	- 146
0,75	4,5	—	+ 22	- 22	- 38	- 56	- 146
0,8	5	—	+ 24	- 24	- 38	- 60	- 155
1	6 and 7	8 and 10	+ 26	- 26	- 40	- 60	- 172
1,25	8	10 and 12	+ 28	- 28	- 42	- 63	- 181
1,5	10	12 to 22	+ 32	- 32	- 45	- 67	- 199
1,75	12	—	+ 34	- 34	- 48	- 71	- 221
2	14 & 16	20 to 33	+ 38	- 38	- 52	- 71	- 231
2,5	18, 20 and 22	—	+ 42	- 42	- 58	- 80	- 250
3	24 and 27	36 to 48	+ 48	- 48	- 63	- 85	- 285
3,5	30 and 33	—	+ 53	- 53	- 70	- 90	- 302
4	36 and 39	52 to 64	+ 60	- 60	- 75	- 95	- 319
4,5	42 and 45	—	+ 63	- 63	- 80	- 100	- 336
5	48 and 52	—	+ 71	- 71	- 85	- 106	- 356
5,5	56 and 60	—	+ 75	- 75	- 90	- 112	- 377
6	64	—	+ 80	- 80	- 95	- 118	- 398

<sup>a</sup> Nominal thread diameters are given for information, the determining characteristic is the thread pitch.

<sup>b</sup> The minimum clearance corresponds to the fundamental deviation.

<sup>c</sup> The maximum clearance corresponds to the fundamental deviation plus the tolerance grade value.

The clearance should be divided by 4 in accordance with [Table B.1](#) in order to get the maximum coating thickness.

### B.5 Compatibility between corrosion resistance and clearance

For compatibility between corrosion resistance and clearance, see [Figure B.4](#).

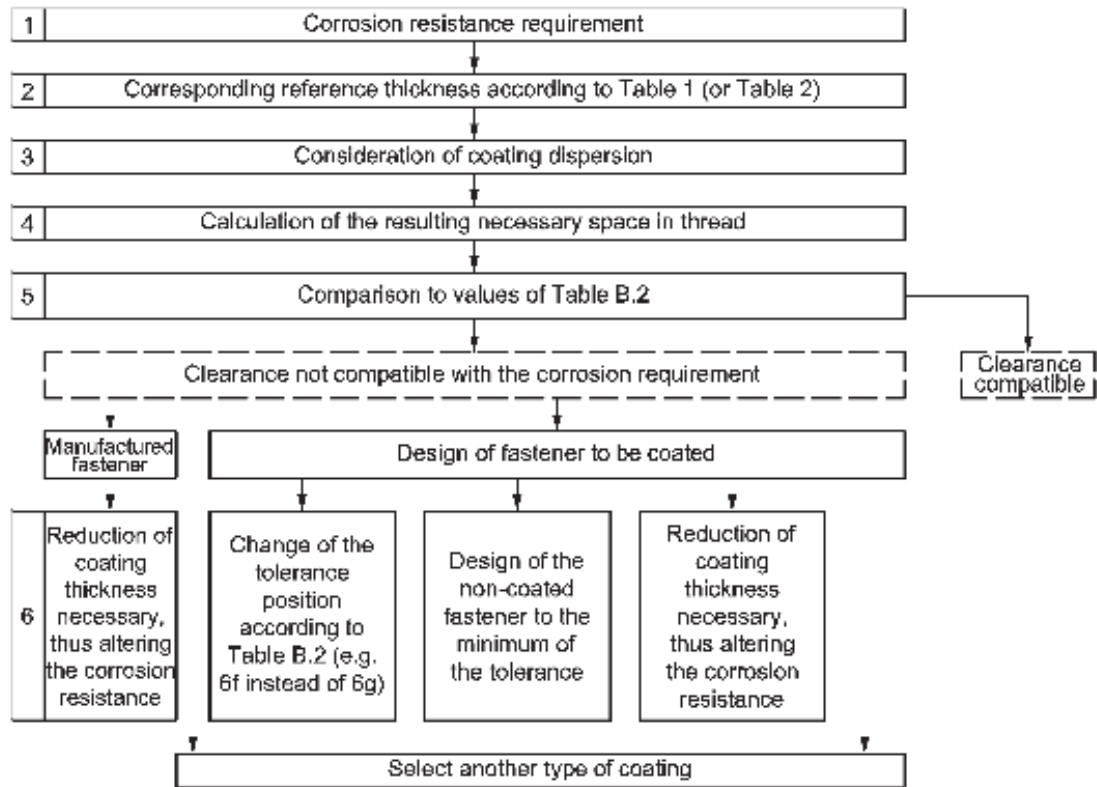

Figure B.4 — Check of compatibility between corrosion resistance and clearance

## B.6 Examples of application

### B.6.1 Example of a bolt with thread tolerance class 6g

Fastener	ISO metric bolts M12 in accordance with ISO 4014, <sup>[4]</sup> coarse pitch of 1,75 mm
Corrosion resistance requirement	480 h
From <a href="#">Table 1</a>	Reference coating thickness: 5 µm
Influence of the possible dispersion (see <a href="#">B.3</a> )	5 µm + 2,5 µm for maximum thickness at pitch diameter, rounded to 8 µm
From <a href="#">Table B.1</a> (8 µm × 4)	32 µm
From <a href="#">Table B.2</a> (tolerance class 6g)	Minimum clearance: 34 µm

**Result** When the calculated value (32 µm) is less or equal to the minimum clearance defined in [Table B.2](#) (34 µm), whatever the dimension of the thread is within tolerance class 6g before coating, the thickness of the coating system is compatible with the requirement.

**B.6.2 Example of a screw with thread tolerance class 6g**

Fastener	ISO metric bolts M6 in accordance with ISO 4017, <sup>[5]</sup> coarse pitch of 1 mm
Corrosion resistance requirement	600 h
From <a href="#">Table 1</a>	Reference coating thickness: 6 µm
Influence of the possible dispersion (see <a href="#">B.3</a> )	6 µm + 3 µm for maximum thickness at pitch diameter
From <a href="#">Table B.1</a> (9 µm × 4)	36 µm
From <a href="#">Table B.2</a> (tolerance class 6g)	Minimum clearance: 26 µm

**Result** The calculated value (36 µm) exceeds the minimum clearance defined in [Table B.2](#) (26 µm), the thickness of the coating system is not compatible with the requirement.

**B.6.3 Example of the same screw as in [B.6.2](#) but with thread tolerance class changed to 6f**

Fastener	ISO metric bolts M6 in accordance with ISO 4017, <sup>[5]</sup> coarse pitch of 1 mm
Corrosion resistance requirement	600 h
From <a href="#">Table 1</a>	Reference coating thickness: 6 µm
Influence of the possible dispersion (see <a href="#">B.3</a> )	6 µm + 3 µm for maximum thickness at pitch diameter
From <a href="#">Table B.1</a> (9 µm × 4)	36 µm
From <a href="#">Table B.2</a> (tolerance class 6f)	Minimum clearance: 40 µm

**Result** The calculated value (36 µm) is now less than the minimum clearance defined in [Table B.2](#) (40 µm). Whatever the dimension of the thread is within tolerance class 6f before coating, the thickness of the coating system is compatible with the requirement.

## Annex C (informative)

### Control of the corrosivity of the cabinet for neutral salt spray test for coated fasteners

#### C.1 Purpose

The purpose of this annex is to check the corrosivity of the cabinet used for neutral salt spray test in accordance with ISO 9227 for fasteners with zinc based coatings (except hot dip galvanization).

Two types of tests are defined in order to:

- determine the corrosivity level as a grade and the conditions under which the cabinet is considered compliant, by controlling the cabinet corrosivity throughout the useful volume, independent of specimens to be tested;
- monitor the cabinet corrosivity between two controls.

**NOTE** The control of the corrosivity level can be used for qualification and acceptance of new neutral salt spray cabinets.

#### C.2 Frequency

The determination of the corrosivity level should be carried out at least once a year, and also prior to the use of the cabinet following major maintenance or repair work on the equipment.

The corrosivity monitoring should be carried out at least once a month.

#### C.3 Operating conditions

##### C.3.1 Parameters

All parameters specified in ISO 9227 should be checked except the calibration method.

##### C.3.2 Reference panels

The reference panels should be made of steel, e.g. CR24 in accordance with ISO 6932,<sup>[2]</sup> coated at least on one surface with a layer of zinc obtained by high-speed continuous hot dip galvanizing.

The zinc thickness should be  $11 \mu\text{m} \pm 1 \mu\text{m}$ . The zinc panels may be oiled for better protection in storage.

The reference panels should be accompanied by a certificate of compliance containing the following:

- the identification of the supplier;
- the identification of the product: coil and melt number;
- the chemical composition and mechanical properties of the substrate metal;
- the thickness of the zinc deposit;
- the reference of the protective oil.

### C.3.3 Preparation of salt solution

#### C.3.3.1 Preparation

In anhydrous form, the sodium chloride should not contain more than 0,2 % (by mass) of impurities in total. It should contain less than 10 mg/kg of nickel and less than 10 mg/kg of copper. Sea salt should not be used so as to avoid sodium iodide.

Using water whose conductivity is less than or equal to 20  $\mu\text{S}/\text{cm}$  at  $(25 \pm 2)^\circ\text{C}$ , dissolve the quantity of sodium chloride required to obtain a concentration of  $(50 \pm 5)$  g/l.

The density of the salt solution, measured at  $(25 \pm 2)^\circ\text{C}$ , should be 1,029  $\text{kg}/\text{dm}^3$  to 1,036  $\text{kg}/\text{dm}^3$ .

#### C.3.3.2 Measurement of pH

pH is measured at  $(25 \pm 2)^\circ\text{C}$  with a pH meter equipped with a high alkalinity glass electrode ( $\pm 0,1$  pH units or less). The electrode should not touch the bottom of the beaker. The solution should be gently stirred for 1 min before reading.

The pH of the salt solution should be 6,3 to 7,4 after a maximum stabilization time of six hours. If this is not the case, the solution cannot be used. The cause should be identified and the source of any impurities eliminated accordingly.

#### C.3.3.3 Filtering

The solution should be clear (observation with the naked eye). If necessary, filter it before introducing it into the tank.

### C.3.4 Preparation of the reference panels

The reference panels should be used within 24 h maximum after the degreasing procedure has been completed. They should be degreased as follows:

- a) Pre-degreasing with acetone using a soft cloth;
- b) Degreasing with ultrasonics in a cleaning solution made up of the following:
  - Sodium bicarbonate ( $\text{NaHCO}_3$ )  $(15 \pm 2)$  g/l;
  - Sodium carbonate ( $\text{Na}_2\text{CO}_3$ )  $(10 \pm 2)$  g/l;
  - Trisodium phosphate ( $\text{Na}_3\text{PO}_4$ )  $(20 \pm 2)$  g/l;
  - Disodium tetraborate decahydrate ( $\text{Na}_2\text{B}_4\text{O}_7 \cdot 10\text{H}_2\text{O}$ )  $(10 \pm 2)$  g/l;
  - Volume adjusted to one litre with demineralized water.

Ultrasonic conditions:

- temperature  $(45 \pm 2)^\circ\text{C}$ ;
- duration  $(7 \pm 1)$  min.

The service life of this degreasing solution is 36 months in an opaque container and in storage conditions ranging from  $0^\circ\text{C}$  to  $40^\circ\text{C}$ . This solution should be stored in a sealed container between uses. One litre of this solution is sufficient for a maximum of 5 panels.

- c) The panel should be removed with tongs before turning off the ultrasonics. It should be rinsed in demineralized or deionized water, then in a clean solvent (ethanol or acetone), then left to dry in the air.

### C.3.5 Protection

It is recommended that the degreased panels are handled wearing gloves. The edges and back of panels should be protected with adhesive tape of the brown-coloured 100 × 38 type, as indicated in the diagram in [Figure C.3](#).

### C.3.6 Position of reference panels and collectors

The support should be made of chemically inert material. It should enable positioning of the panels in line with an angle of  $(20 \pm 5)^\circ$  in relation to the vertical. The centre of each panel should be positioned at the mean specimen exposure height, with the corrosion side facing the spray device. The number and relative position of the panels vary in accordance with the test method and cabinet design, see [Figures C.1 to C.3](#):

- at least three panels for the annual characterization. The panels should be positioned  $1/4$ ,  $1/2$  and  $3/4$  of the distance between the spray nozzle and the most distant cabinet wall;
- at least one panel during the monthly monitoring. The panel should be positioned halfway between the spray and the most distant cabinet wall.

The collectors should be placed in accordance with [Figures C.1 to C.3](#).

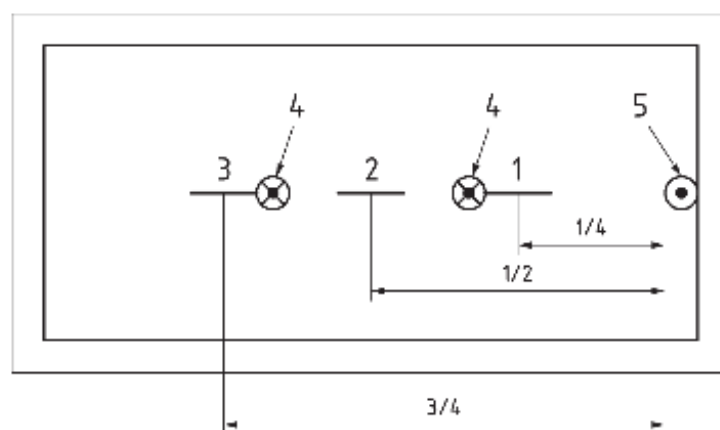

Key	
1, 2, 3	panel
4	collecting cylinder
5	spray nozzle

Figure C.1 — Off-centred spray cabinet

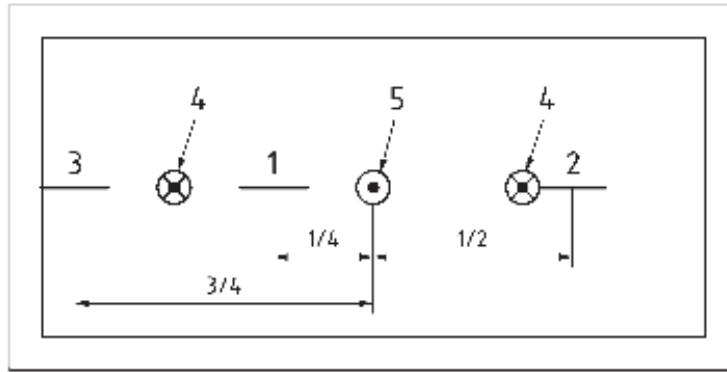

- Key**
- 1, 2, 3 panel
  - 4 collecting cylinder
  - 5 spray nozzle

**Figure C.2 — Centred spray cabinet**

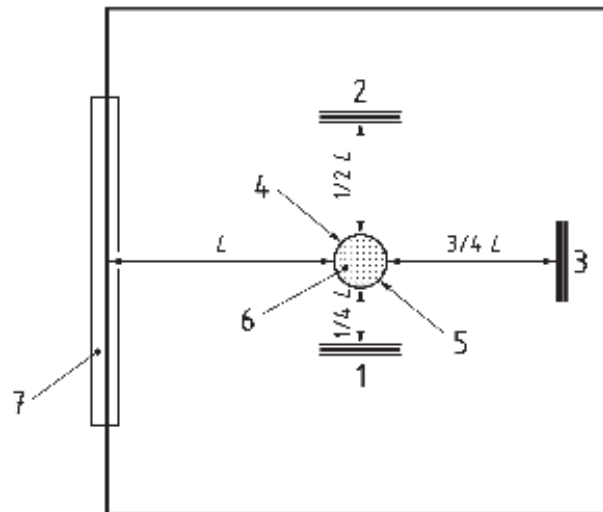

- Key**
- 1, 2, 3 panel
  - 4, 5 collecting cylinder
  - 6 spray nozzle
  - 7 door

**Figure C.3 — Centred spray cabinet**

### C.3.7 Filling of the cabinet

During the annual characterization, the cabinet should only contain the reference panels.

Monthly monitoring may be conducted during normal operation of the cabinet. The other exposed specimens should not obstruct the reference panel.

### C.3.8 Determination of the corroded surface

The control mask shown in [Figure C.4](#) should be reproduced on a transparency. The mask should be placed on the reference panel.

Dimensions in millimetres

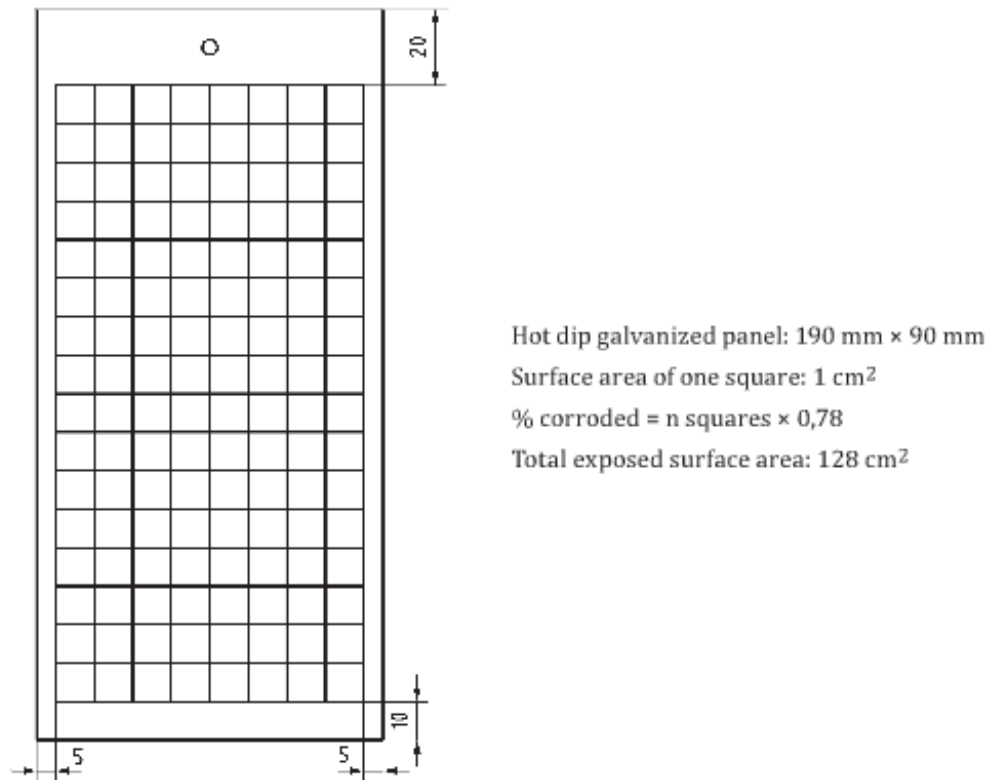

**Figure C.4 — Protection and control mask for reference panels**

A square is reported to be oxidized as soon as it shows one point of red oxidation (flow included). See examples in [C.5](#).

The visual check should be made every  $(24 \pm 1)$  h on the non-rinsed, still wet panels.

The final check should be made after a period of 72 h. It is recommended to start the test on Friday.

If one of the panels shows evidence of red oxidation during the 72 h check, it is necessary to repeat the test the following Monday and to check it every 24 h.

For the annual characterization, the cabinet should be open during 30 min per day after the period of 72 h.

For the monthly monitoring, each opening should not exceed 60 min. The open duration is not deducted.

### C.3.9 Results

RRT (Red Rust Time) is the time taken for the rusting level to exceed 5 % (i.e. a minimum of six squares showing red oxidation).

The cabinet corrosivity level is evaluated using a grading system of A to D in accordance with [Table C.1](#).

**Table C.1 — Grading system for the evaluation of the cabinet corrosivity level**

Red Rust Time (RRT) h	Grade	Compliance
$RRT \leq 72$	A	Not compliant
$72 < RRT \leq 96$	B	Compliant
$96 < RRT \leq 120$	C	
$RRT > 120$	D	Not compliant
NOTE A cabinet is considered to be compliant when the grade is equal to B or C.		

#### C.4 Example of quotation of corrosivity

The top of the mask is placed exactly at the top of the reference panel in accordance with its orientation in the cabinet during the test. An example of quotation of corrosivity is shown in [Figure C.5](#).

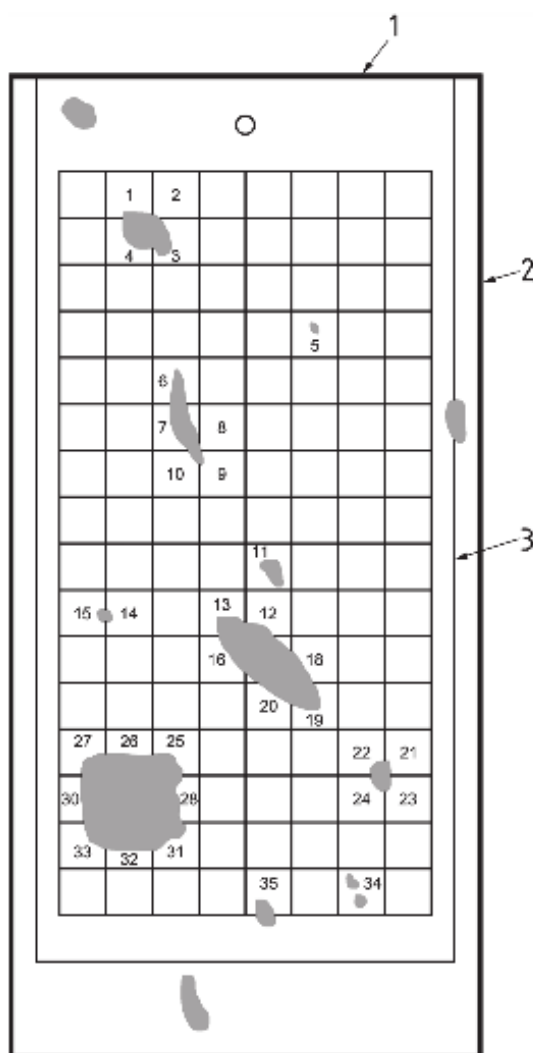

**Key**

1 top of the mask and top of the panel

2 reference panel

3 control mask

35 squares showing red rust: the percentage of oxidation is 27,3 % (35 × 0,78)

**Figure C.5 — Example of quotation of corrosivity**

### C.5 Report form for the annual control and monthly monitoring of the cabinet corrosivity level

Type of test: Monthly monitoring <input type="checkbox"/> Annual control <input type="checkbox"/>
Test start date ..... Cabinet identification number .....
Reference panel batch number .....

#### Condensate check

Volume collected in ml/h <sup>a</sup>		
Collector 1	Collector 2	Collector 3

<sup>a</sup> Average measurement over the entire test duration (opening time included). For a horizontal collecting area of 80 cm<sup>2</sup>: (1,5 ± 0,5) ml/h in accordance with ISO 9227.

NOTE The collector number is the same as the panel number.

#### Determination of the corrosivity level

Red Rust Time (RRT) h	Grade	Evidence of red oxidation: % measured on the control mask		
		Panel 1	Panel 2	Panel 3
RRT ≤ 72	A			
72 < RRT ≤ 96	B			
96 < RRT ≤ 120	C			
RRT > 120	D			
<b>Result (Grade)</b>				

#### Conclusion for the corrosivity of the chamber

CONFORMITY OF ALL PARAMETERS <input type="checkbox"/>	NON CONFORMITY <input type="checkbox"/>	
Comments		
Operator	Signature	Date

## Bibliography

- [1] ISO 965-1, *ISO general purpose metric screw threads — Tolerances — Part 1: Principles and basic data*
- [2] ISO 965-2, *ISO general purpose metric screw threads — Tolerances — Part 2: Limits of sizes for general purpose external and internal screw threads — Medium quality*
- [3] ISO 965-3, *ISO general purpose metric screw threads — Tolerances — Part 3: Deviations for constructional screw threads*
- [4] ISO 4014, *Hexagon head bolts — Product grades A and B*
- [5] ISO 4017, *Hexagon head screws — Product grades A and B*
- [6] ISO 4032, *Hexagon regular nuts (style 1) — Product grades A and B*
- [7] ISO 6932, *Cold-reduced carbon steel strip with a maximum carbon content of 0,25 %*
- [8] ISO 7089, *Plain washers — Normal series — Product grade A*
- [9] ISO 16426, *Fasteners — Quality assurance system*