

BS EN 14399-4:2015



BSI Standards Publication

# High-strength structural bolting assemblies for preloading

Part 4: System HV — Hexagon bolt and nut  
assemblies

**bsi.**

...making excellence a habit.™

### **National foreword**

This British Standard is the UK implementation of EN 14399-4:2015. It supersedes BS EN 14399-4:2005 which is withdrawn.

The UK participation in its preparation was entrusted to Technical Committee FME/9/-/2, Fasteners for structural bolting.

A list of organizations represented on this committee can be obtained on request to its secretary.

This publication does not purport to include all the necessary provisions of a contract. Users are responsible for its correct application.

© The British Standards Institution 2015. Published by BSI Standards Limited 2015

ISBN 978 0 580 81780 9

ICS 21.060.01; 21.060.10; 21.060.20

**Compliance with a British Standard cannot confer immunity from legal obligations.**

This British Standard was published under the authority of the Standards Policy and Strategy Committee on 28 February 2015.

### **Amendments issued since publication**

Date	Text affected
------	---------------

---

EUROPEAN STANDARD

**EN 14399-4**

NORME EUROPÉENNE

EUROPÄISCHE NORM

February 2015

ICS 21.060.01

Supersedes EN 14399-4:2005

English Version

## High-strength structural bolting assemblies for preloading - Part 4: System HV - Hexagon bolt and nut assemblies

Boulonnerie de construction métallique à haute résistance  
apte à la précontrainte - Partie 4: Système HV - Boulons à  
tête hexagonale (vis + écrou)

Hochfeste vorspannbare Garnituren für  
Schraubverbindungen im Metallbau - Teil 4: System HV -  
Garnituren aus Sechskantschrauben und -muttern

This European Standard was approved by CEN on 18 October 2014.

CEN members are bound to comply with the CEN/CENELEC Internal Regulations which stipulate the conditions for giving this European Standard the status of a national standard without any alteration. Up-to-date lists and bibliographical references concerning such national standards may be obtained on application to the CEN-CENELEC Management Centre or to any CEN member.

This European Standard exists in three official versions (English, French, German). A version in any other language made by translation under the responsibility of a CEN member into its own language and notified to the CEN-CENELEC Management Centre has the same status as the official versions.

CEN members are the national standards bodies of Austria, Belgium, Bulgaria, Croatia, Cyprus, Czech Republic, Denmark, Estonia, Finland, Former Yugoslav Republic of Macedonia, France, Germany, Greece, Hungary, Iceland, Ireland, Italy, Latvia, Lithuania, Luxembourg, Malta, Netherlands, Norway, Poland, Portugal, Romania, Slovakia, Slovenia, Spain, Sweden, Switzerland, Turkey and United Kingdom.



EUROPEAN COMMITTEE FOR STANDARDIZATION  
COMITÉ EUROPÉEN DE NORMALISATION  
EUROPÄISCHES KOMITEE FÜR NORMUNG

**CEN-CENELEC Management Centre: Avenue Marnix 17, B-1000 Brussels**

## Contents

	Page
Foreword.....	3
Introduction.....	4
<b>1 Scope .....</b>	<b>6</b>
<b>2 Normative references .....</b>	<b>6</b>
<b>3 Bolts .....</b>	<b>7</b>
3.1 Dimensions of bolts.....	7
3.2 Specifications for bolts and reference standards .....	10
3.3 Marking of bolts .....	10
<b>4 Nuts .....</b>	<b>11</b>
4.1 Dimensions of nuts.....	11
4.2 Specification for nuts and reference standards .....	13
4.3 Decarburization of the nut thread .....	13
4.4 Marking of nuts .....	13
<b>5 Designation of the bolt/nut assemblies.....</b>	<b>14</b>
<b>6 Associated washers .....</b>	<b>14</b>
<b>7 Functional characteristics of the bolt/nut/washers assembly .....</b>	<b>14</b>
7.1 General.....	14
7.2 Maximum individual value of the bolt force during fitness for purpose test ( $F_{bi,max}$ ) .....	15
7.3 Values of angle $\Delta\theta_1$ .....	15
7.4 Values of angle $\Delta\theta_2$ .....	15
7.5 Individual values of the $k$ -factor ( $k_i$ ), mean value of the $k$ -factor ( $k_m$ ) and coefficient of variation of the $k$ -factor ( $V_k$ ) .....	16
7.5.1 Individual values of the $k$ -factor ( $k_i$ ) for $k$ -class K1 .....	16
7.5.2 Mean value of the $k$ -factor ( $k_m$ ) and coefficient of variation of the $k$ -factor ( $V_k$ ) for $k$ -class K2 .....	16
<b>Annex A (normative) Clamp lengths and Grip lengths .....</b>	<b>17</b>
<b>Bibliography .....</b>	<b>20</b>

## Foreword

This document (EN 14399-4:2015) has been prepared by Technical Committee CEN/TC 185 "Fasteners", the secretariat of which is held by DIN.

This European Standard shall be given the status of a national standard, either by publication of an identical text or by endorsement, at the latest by August 2015 and conflicting national standards shall be withdrawn at the latest by November 2016.

Attention is drawn to the possibility that some of the elements of this document may be the subject of patent rights. CEN [and/or CENELEC] shall not be held responsible for identifying any or all such patent rights.

This document supersedes EN 14399-4:2005.

In comparison with EN 14399-4:2005, the following modifications have been made:

- Table 1 containing the overview of the composition of bolting assemblies and component marking has been added;
- the use of washers in accordance with EN 14399-5 was deleted;
- the coefficient of variation of the  $k$ -factor,  $V_k$ , has changed from 0,10 to 0,06;
- specifications for the designation of the bolting assemblies have been revised;
- in Annex A detailed specifications on grip lengths has been added.

EN 14399 consists of the following parts, under the general title *High-strength structural bolting assemblies for preloading*:

- *Part 1: General requirements*;
- *Part 2: Suitability for preloading*;
- *Part 3: System HR — Hexagon bolt and nut assemblies*;
- *Part 4: System HV — Hexagon bolt and nut assemblies*;
- *Part 5: Plain washers*;
- *Part 6: Plain chamfered washers*;
- *Part 7: System HR — Countersunk head bolt and nut assemblies*;
- *Part 8: System HV — Hexagon fit bolt and nut assemblies*;
- *Part 9: System HR or HV — Direct tension indicators for bolt and nut assemblies*;
- *Part 10: System HRC — Bolt and nut assemblies with calibrated preload*.

According to the CEN-CENELEC Internal Regulations, the national standards organizations of the following countries are bound to implement this European Standard: Austria, Belgium, Bulgaria, Croatia, Cyprus, Czech Republic, Denmark, Estonia, Finland, Former Yugoslav Republic of Macedonia, France, Germany, Greece, Hungary, Iceland, Ireland, Italy, Latvia, Lithuania, Luxembourg, Malta, Netherlands, Norway, Poland, Portugal, Romania, Slovakia, Slovenia, Spain, Sweden, Switzerland, Turkey and the United Kingdom.

## Introduction

This document on structural bolting reflects the situation in Europe where two technical solutions exist to achieve the necessary ductility of bolt/nut/washers assemblies. These solutions consist of two different systems (HR and HV) of bolt/nut/washer assemblies, see Table 1. Both systems are well proven and it is the responsibility of the experts using structural bolting whether they use the one or the other system.

It is, however, important for the performance of the assembly to avoid mixing up the components of both systems. Therefore, bolts and nuts for both systems are standardized in one single part of this European Standard each and the marking of the components of the same system is uniform.

Preloaded bolted assemblies are very sensitive to differences in manufacture and lubrication. Therefore it is important that the bolting assemblies are supplied by one manufacturer who is always responsible for the functionality of the bolting assemblies.

For the same reason it is important that coating of the bolting assemblies is under the control of one manufacturer.

Beside the mechanical properties of the components, the functionality of the bolting assemblies requires that the specified preload can be achieved if the bolting assemblies are tightened with a suitable procedure. For this purpose a test method for the suitability of the bolting assemblies for preloading was created, which will demonstrate whether the functionality of the bolting assemblies is fulfilled.

It should be pointed out that compared to ISO 272 the widths across flats (large series) for M12 and M20 have been changed to 22 mm and 32 mm respectively. These changes are justified by the following reasons.

Under the specific conditions of structural bolting, the compressive stresses under the bolt head or nut for the sizes M12 may become too large with the width across flats of 21 mm, especially if the washer is fitted eccentrically to the bolt axis.

For the size M20, the width across flats of 34 mm is very difficult to be produced. The change to 32 mm is primarily motivated by economics but it should also be pointed out that the width across flats of 32 mm was already common practice in Europe.

Table 1 — Composition of high-strength structural bolting assemblies and component marking

Type of bolting assembly		System HR				System HV		System HRC	
General requirements		EN 14399-1							
Suitability for preloading		EN 14399-2 and, if any, additional testing specified in the product standard							
Bolt and nut		EN 14399-3		EN 14399-7		EN 14399-4	EN 14399-8	EN 14399-10	
Marking	Bolt	HR8.8	HR10.9	HR8.8	HR10.9	HV10.9	HVP10.9	HRC10.9	
	Nut	HR8 or HR10	HR10	HR8 or HR10	HR10	HV10	HV10	HR10	HRD10
Washers		EN 14399-5 <sup>a</sup> or EN 14399-6				EN 14399-6		EN 14399-5 <sup>a</sup> or EN 14399-6	
Marking		H or HR <sup>b</sup>				H or HV <sup>b</sup>		H or HR <sup>b</sup>	H or HR <sup>b</sup> or HD <sup>c</sup>
Direct tension indicator and nut face washer or bolt face washer, if any		EN 14399-9						Not applicable	
Marking	Direct tension indicator	H8	H10	H8	H10	H10			
	Nut face washer	HN				HN			
	Bolt face washer	HB		Not applicable		HB			
<sup>a</sup> EN 14399-5 can only be used under the nut.									
<sup>b</sup> At the choice of the manufacturer.									
<sup>c</sup> Mandatory mark for washers with enlarged outer diameter according to EN 14399-5 only.									

## 1 Scope

This European Standard specifies together with EN 14399-1 and EN 14399-2, the requirements for assemblies of high-strength structural bolts and nuts of system HV suitable for preloaded joints with large widths across flats, thread sizes M12 to M36 and property classes 10.9/10.

Bolting assemblies in accordance with this document have been designed to allow preloading of at least  $0,7 f_{ub} \times A_s$ <sup>1)</sup> according to EN 1993-1-8 (Eurocode 3) and to obtain ductility predominantly by plastic deformation of the engaged threads. For this purpose the components have the following characteristics:

- nut height approximately  $0,8 d$ ;
- bolt with short thread length.

Bolting assemblies in accordance with this document include washers according to EN 14399-6.

NOTE Attention is drawn to the importance of ensuring that the bolting assemblies are correctly used if satisfactory results are to be obtained. For recommendations concerning proper application, reference to EN 1090-2 is made.

General requirements and requirements for suitability for preloading are specified in EN 14399-2.

Clamp lengths and grip lengths for the bolting assemblies are specified in the normative Annex A.

## 2 Normative references

The following documents, in whole or in part, are normatively referenced in this document and are indispensable for its application. For dated references, only the edition cited applies. For undated references, the latest edition of the referenced document (including any amendments) applies.

EN 14399-1, *High-strength structural bolting assemblies for preloading - Part 1: General requirements*

EN 14399-2, *High-strength structural bolting assemblies for preloading - Part 2: Suitability for preloading*

EN 14399-5, *High-strength structural bolting assemblies for preloading - Part 5: Plain washers*

EN 14399-6, *High-strength structural bolting assemblies for preloading - Part 6: Plain chamfered washers*

EN 26157-1, *Fasteners - Surface discontinuities - Part 1: Bolts, screws and studs for general requirements (ISO 6157-1)*

EN ISO 898-1, *Mechanical properties of fasteners made of carbon steel and alloy steel - Part 1: Bolts, screws and studs with specified property classes - Coarse thread and fine pitch thread (ISO 898-1)*

EN ISO 898-2, *Mechanical properties of fasteners made of carbon steel and alloy steel - Part 2: Nuts with specified property classes - Coarse thread and fine pitch thread (ISO 898-2)*

EN ISO 3269, *Fasteners - Acceptance inspection (ISO 3269)*

EN ISO 4759-1, *Tolerances for fasteners - Part 1: Bolts, screws, studs and nuts - Product grades A, B and C (ISO 4759-1)*

EN ISO 6157-2, *Fasteners - Surface discontinuities - Part 2: Nuts (ISO 6157-2)*

---

1)  $f_{ub}$  is the nominal tensile strength ( $R_m$ ) and  $A_s$  the nominal stress area of the bolt.

EN ISO 10684, *Fasteners - Hot dip galvanized coatings (ISO 10684)*

ISO 261, *ISO general purpose metric screw threads - General plan*

ISO 965-2, *ISO general purpose metric screw threads - Tolerances - Part 2: Limits of sizes for general purpose external and internal screw threads - Medium quality*

ISO 965-5, *ISO general purpose metric screw threads - Tolerances - Part 5: Limits of sizes for internal screw threads to mate with hot-dip galvanized external screw threads with maximum size of tolerance position  $h$  before galvanizing*

### 3 Bolts

#### 3.1 Dimensions of bolts

See Figure 1 and Table 2.

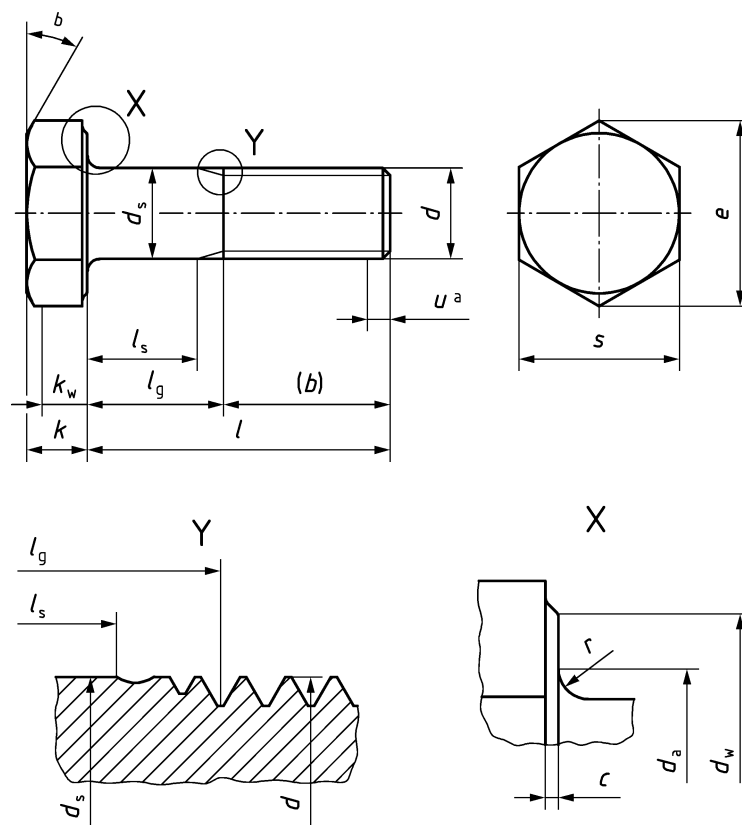

#### Key

- a incomplete thread  $u \leq 2P$
- b  $15^\circ$  to  $30^\circ$

**Figure 1 — Dimensions of bolts**

The difference between  $l_g$  and  $l_s$  should not be less than  $1,5 P$ .

For coated bolts, the dimensions apply prior to coating.

Table 2 — Dimensions of bolts

Dimensions in millimetres

Thread ( <i>d</i> )		M12	M16	M20	M22	M24	M27	M30	M36											
<i>p</i> <sup>a</sup>		1,75	2	2,5	2,5	3	3	3,5	4											
<i>b</i> (ref.)		23	28	33	34	39	41	44	52											
<i>c</i>	min.	0,4	0,4	0,4	0,4	0,4	0,4	0,4	0,4											
	max.	0,6	0,6	0,8	0,8	0,8	0,8	0,8	0,8											
<i>d</i> <sub>a</sub>		max.	15,2	19,2	24,0	26,0	28,0	32,0	35,0	41,0										
<i>d</i> <sub>s</sub>	nom.	12	16	20	22	24	27	30	36											
	min.	11,30	15,30	19,16	21,16	23,16	26,16	29,16	35,00											
	max.	12,70	16,70	20,84	22,84	24,84	27,84	30,84	37,00											
<i>d</i> <sub>w</sub>	min.	20,1	24,9	29,5	33,3	38,0	42,8	46,6	55,9											
	max.	<sup>b</sup>	<sup>b</sup>	<sup>b</sup>	<sup>b</sup>	<sup>b</sup>	<sup>b</sup>	<sup>b</sup>	<sup>b</sup>											
<i>e</i>		min.	23,91	29,56	35,03	39,55	45,20	50,85	55,37	66,44										
<i>k</i>	nom.	8	10	13	14	15	17	19	23											
	min.	7,55	9,25	12,10	13,10	14,10	16,10	17,95	21,95											
	max.	8,45	10,75	13,90	14,90	15,90	17,90	20,05	24,05											
<i>k</i> <sub>w</sub>		min.	5,28	6,47	8,47	9,17	9,87	11,27	12,56	15,36										
<i>r</i>		min.	1,2	1,2	1,5	1,5	1,5	2,0	2,0	2,0										
<i>s</i>	max.	22	27	32	36	41	46	50	60											
	min.	21,16	26,16	31,00	35,00	40,00	45,00	49,00	58,80											
<i>l</i>		<i>l</i> <sub>s</sub> and <i>l</i> <sub>g</sub> <sup>c</sup>																		
		<i>l</i> <sub>s</sub>	<i>l</i> <sub>g</sub>	<i>l</i> <sub>s</sub>	<i>l</i> <sub>g</sub>	<i>l</i> <sub>s</sub>	<i>l</i> <sub>g</sub>	<i>l</i> <sub>s</sub>	<i>l</i> <sub>g</sub>	<i>l</i> <sub>s</sub>	<i>l</i> <sub>g</sub>	<i>l</i> <sub>s</sub>	<i>l</i> <sub>g</sub>	<i>l</i> <sub>s</sub>	<i>l</i> <sub>g</sub>	<i>l</i> <sub>s</sub>	<i>l</i> <sub>g</sub>	<i>l</i> <sub>s</sub>	<i>l</i> <sub>g</sub>	
nom.	min.	max.	min.	max.	min.	max.	min.	max.	min.	max.	min.	max.	min.	max.	min.	max.	min.	max.	min.	max.
<b>35</b>	33,75	36,25	6,75	12																
<b>40</b>	38,75	41,25	11,75	17	6	12														
<b>45</b>	43,75	46,25	16,75	22	11	17	4,5	12												
<b>50</b>	48,75	51,25	21,75	27	16	22	9,5	17	8,5	16										
<b>55</b>	53,5	56,5	26,75	32	21	27	14,5	22	13,5	21										
<b>60</b>	58,5	61,5	31,75	37	26	32	19,5	27	18,5	26	12	21								
<b>65</b>	63,5	66,5	36,75	42	31	37	24,5	32	23,5	31	17	26								
<b>70</b>	68,5	71,5	41,75	47	36	42	29,5	37	28,5	36	22	31	20	29						
<b>75</b>	73,5	76,5	46,75	52	41	47	34,5	42	33,5	41	27	36	25	34	20,5	31				
<b>80</b>	78,5	81,5	51,75	57	46	52	39,5	47	38,5	46	32	41	30	39	25,5	36				
<b>85</b>	83,25	86,75	56,75	62	51	57	44,5	52	43,5	51	37	46	35	44	30,5	41	21	33		
<b>90</b>	88,25	91,75	61,75	67	56	62	49,5	57	48,5	56	42	51	40	49	35,5	46	26	38		
<b>95</b>	93,25	96,75	66,75	72	61	67	54,5	62	53,5	61	47	56	45	54	40,5	51	31	43		
<b>100</b>	98,25	101,75			66	72	59,5	67	58,5	66	52	61	50	59	45,5	56	36	48		
<b>105</b>	103,25	106,75			71	77	64,5	72	63,5	71	57	66	55	64	50,5	61	41	53		

110	108,25	111,75			76	82	69,5	77	68,5	76	62	71	60	69	55,5	66	46	58
115	113,25	116,75			81	87	74,5	82	73,5	81	67	76	65	74	60,5	71	51	63
120	118,25	121,75			86	92	79,5	87	78,5	86	72	81	70	79	65,5	76	56	68
125	123	127			91	97	84,5	92	83,5	91	77	86	75	84	70,5	81	61	73
130	128	132			96	102	89,5	97	88,5	96	82	91	80	89	75,5	86	66	78
135	133	137					94,5	102	93,5	101	87	96	85	94	80,5	91	71	83
140	138	142					99,5	107	98,5	106	92	101	90	99	85,5	96	76	88
145	143	147					104,5	112	103,5	111	97	106	95	104	90,5	101	81	93
150	148	152					109,5	117	108,5	116	102	111	100	109	95,5	106	86	98
155	153	159					114,5	122	113,5	121	107	116	105	114	100,5	111	91	103
160	158	164							118,5	126	112	121	110	119	105,5	116	96	108
165	163	169							123,5	131	117	126	115	124	110,5	121	101	113
170	168	174									122	131	120	129	115,5	126	106	118
175	173	179									127	136	125	134	120,5	131	111	123
180	178	184									132	141	130	139	125,5	136	116	128
185	182,7	189,6									137	146	135	144	130,5	141	121	133
190	187,7	194,6									142	151	140	149	135,5	146	126	138
195	192,7	199,6									147	156	145	154	140,5	151	131	143
200	197,7	204,6											150	159	147,5	156	136	148

NOTE Preferred lengths are defined in terms of lengths  $l_{s,min}$  and  $l_{g,max}$ .

<sup>a</sup>  $P$  is the pitch of thread

<sup>b</sup>  $d_{w,max} = s_{actual}$

<sup>c</sup>  $l_{g,max} = l_{nom} - b$   
 $l_{s,min} = l_{g,max} - 3P$

### 3.2 Specifications for bolts and reference standards

Table 3 — Specifications for bolts and reference standards

Material	Steel	
General requirements	EN 14399-1 and EN 14399-2	
Thread	Tolerance class	6g <sup>a</sup>
	International Standards	ISO 261, ISO 965-2
Mechanical properties	Property class	10.9
	European Standard	EN ISO 898-1
Tolerances	Product grade	C except for dimensions <i>c</i> and <i>r</i> Tolerance for lengths ≥ 155 mm: $\begin{matrix} +IT_{17} \\ -1/2IT_{17} \end{matrix}$
	European Standard	EN ISO 4759-1
Finish — Coating <sup>b</sup>	Uncoated	as processed <sup>c</sup>
	Hot dip galvanized	EN ISO 10684
	Others	to be agreed <sup>d</sup>
Surface integrity	Limits for surface discontinuities as specified in EN 26157-1.	
Acceptability	For acceptance procedure, see EN ISO 3269.	
<sup>a</sup> The tolerance class specified applies to bolts without or before any coating. Hot-dip galvanized bolts are intended for assembly with nuts tapped oversize to 6AZ.		
<sup>b</sup> Attention is drawn to the need to consider the risk of hydrogen embrittlement in the case of bolts of property class 10.9, when selecting an appropriate surface treatment process (e.g. cleaning and coating), see the relevant coating standards.		
<sup>c</sup> “As processed” means the normal finish resulting from manufacture with a light coating of oil.		
<sup>d</sup> Other coatings may be negotiated between the purchaser and the manufacturer provided they do not impair the mechanical properties or the functional characteristics. Coatings of cadmium or cadmium alloys are not permitted.		

### 3.3 Marking of bolts

High-strength structural bolts according to this document shall be marked with:

- a) Property class marking in accordance with EN ISO 898-1 and the letters HV.

EXAMPLE 10.9 HV.

- b) Identification mark of the manufacturer of the bolting assembly.

It is permissible for the marking to be either embossed or indented on the top surface of the head. For bolt marking, see Figure 2:

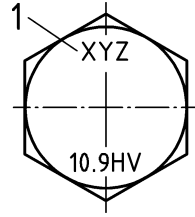

**Key**

- 1 identification mark of the manufacturer of the bolting assembly

**Figure 2 — Example of bolt marking**

## 4 Nuts

### 4.1 Dimensions of nuts

See Figure 3 and Table 4.

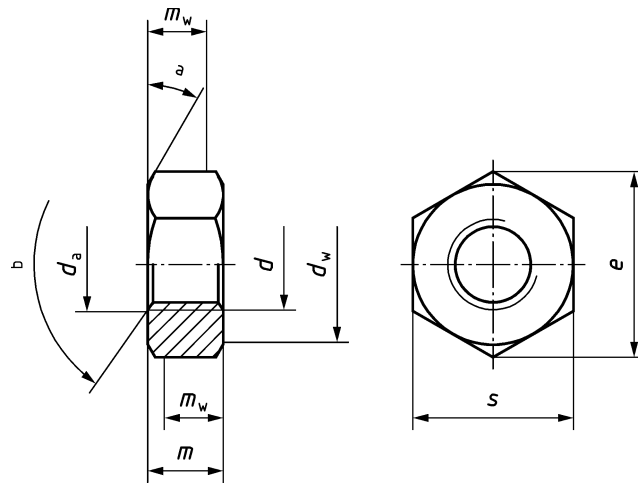

**Key**

- a 15° to 30°  
b 110° to 130°

**Figure 3 — Dimensions of nuts**

For coated nuts, the dimensions apply prior of coating.

Table 4 — Dimensions of nuts

Dimensions in millimetres

Thread ( <i>d</i> )	M12	M16	M20	M22	M24	M27	M30	M36	
$P^a$	1,75	2	2,5	2,5	3	3	3,5	4	
$d_a$	max.	13,0	17,3	21,6	23,7	25,9	29,1	32,4	38,9
	min.	12	16	20	22	24	27	30	36
$d_w$	max.	<sup>b</sup>	<sup>b</sup>	<sup>b</sup>	<sup>b</sup>	<sup>b</sup>	<sup>b</sup>	<sup>b</sup>	<sup>b</sup>
	min.	20,1	24,9	29,5	33,3	38,0	42,8	46,6	55,9
$e$	min.	23,91	29,56	35,03	39,55	45,20	50,85	55,37	66,44
$m$	nom. = max.	10	13	16	18	20	22	24	29
	min.	9,64	12,30	14,90	16,90	18,70	20,70	22,70	27,70
$m_w$	min.	7,71	9,84	11,92	13,52	14,96	16,56	18,16	22,16
$s$	max.	22	27	32	36	41	46	50	60
	min.	21,16	26,16	31,00	35,00	40,00	45,00	49,00	58,80
<sup>a</sup> $P$ is the pitch of thread. <sup>b</sup> $d_{w,max} = s_{actual}$									

## 4.2 Specification for nuts and reference standards

Table 5 — Specifications for nuts and reference standards

Material		Steel		
<b>General requirements</b>		EN 14399-1 and EN 14399-2		
<b>Thread</b>	Coating of the bolt	Uncoated	Hot dip galvanized	Others
	Tolerance class of the nut	6H	6AZ	6H <sup>a</sup>
	International Standards	ISO 261, ISO 965-2	ISO 261, ISO 965-5	ISO 261, ISO 965-2, ISO 965-5
<b>Mechanical properties</b>	Property class	10		
	European Standard	EN ISO 898-2		
<b>Tolerances</b>	Product grade	B		
	European Standard	EN ISO 4759-1		
<b>Finish — Coating</b>	Uncoated	As processed <sup>b</sup>		
	Hot dip galvanized	EN ISO 10684		
	Others	to be agreed <sup>c</sup>		
<b>Surface integrity</b>		Limits for surface discontinuities as specified in EN ISO 6157-2.		
<b>Acceptability</b>		For acceptance procedure, see EN ISO 3269.		
<sup>a</sup> For other coatings that need an increased fundamental deviation and according to the relevant standard, oversize tapped nuts with a thread tolerance class up to 6AZ may be used.				
<sup>b</sup> “As processed“ means the normal finish resulting from manufacture with a light coating of oil.				
<sup>c</sup> Other coatings may be negotiated between the purchaser and the manufacturer provided they do not impair the mechanical properties or the functional characteristics. Coatings of cadmium or cadmium alloys are not permitted.				

### 4.3 Decarburization of the nut thread

The decarburization of the nut thread, when measured in analogy to external threads as given in EN ISO 898-1, shall not exceed  $G = 0,015$  mm.

### 4.4 Marking of nuts

High-strength structural nuts according to this document shall be marked with:

- a) Property class marking in accordance with EN ISO 898-2 and the letters HV.

EXAMPLE 10 HV.

- b) The identification mark of the manufacturer of the bolting assembly.

The marking shall be indented on either bearing face. For nut marking, see Figure 4:

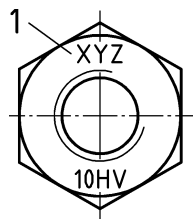

**Key**

1 identification mark of the manufacturer of the bolting assembly

**Figure 4 — Example of nut marking**

## 5 Designation of the bolt/nut assemblies

The designation of bolt/nut assemblies is specified in this clause. The complete designation for bolting assemblies includes washers specified in EN 14399-6.

**EXAMPLE 1** Designation of a bolt/nut assembly for high strength structural bolting for preloading, system HV, consisting of a hexagon bolt with large width across flats, with thread M16, nominal length  $l = 80$  mm and property class 10.9 and a hexagon nut with large width across flats, with thread M16 and property class 10, with surface finish „as processed“, according to  $k$ -class K0 (e.g.: For use with direct tension indicator in accordance with EN 14399-9.):

Bolt/nut assembly EN 14399-4 — HV — M16 × 80 — 10.9/10 — K0

**EXAMPLE 2** Designation of a bolt/nut assembly for high strength structural bolting for preloading, system HV, consisting of a hexagon head bolt with large width across flats, with thread M16, nominal length  $l = 80$  mm and property class 10.9 and a hexagon nut with large width across flats, with thread M16 and property class 10, with hot dip galvanized coatings (tZn), according to  $k$ -class K2:

Bolt/nut assembly EN 14399-4 — HV — M16 × 80 — 10.9/10 — tZn — K2

## 6 Associated washers

**Bolt/nut assemblies according to this document shall be assembled with washers specified in EN 14399-6.**

## 7 Functional characteristics of the bolt/nut/washers assembly

### 7.1 General

The functional characteristics of the bolt/nut/washers assemblies according to 7.2 and 7.4 shall be achieved for all  $k$ -classes when tested in accordance with EN 14399-2.

Additionally for K1, 7.5.1 shall apply and for K2, 7.5.2 shall apply.

Minimum clamp lengths are specified in Annex A (see Table A.1).

**NOTE** For further background information as to these functional characteristics, see EN 14399-2.

The bolting assembly shall be suitably lubricated in the as delivered condition, to ensure that seizure will not take place during tightening of the assembly and that the required preload is obtained.

## 7.2 Maximum individual value of the bolt force during fitness for purpose test ( $F_{bi,max}$ )

The following applies:

$$F_{bi,max} \geq 0,9 f_{ub} \times A_S$$

where

$f_{ub}$  is the nominal tensile strength ( $R_m$ )

$A_S$  is the nominal stress area of the bolt.

## 7.3 Values of angle $\Delta\theta_1$

$\Delta\theta_1$  is the angle by which the nut shall be turned starting from a preload of  $0,7 f_{ub} \times A_S$  until  $F_{bi,max}$  is reached.

The values indicated in Table 6 are for information only.

**Table 6 — Values for  $\Delta\theta_1$**

Clamp length $\Sigma t^a$	$\Delta\theta_1$ min.
$\Sigma t < 2 d$	90°
$2 d \leq \Sigma t < 6 d$	120°
$6 d \leq \Sigma t \leq 10 d$	150°

<sup>a</sup>  $\Sigma t$  is the total thickness of the clamped parts including washers.

## 7.4 Values of angle $\Delta\theta_2$

$\Delta\theta_2$  is the angle by which the nut shall be turned, starting from a preload of  $0,7 f_{ub} \times A_S$  through  $F_{bi,max}$  and until  $F_{bi}$  has dropped to  $0,7 f_{ub} \times A_S$ .

The values for  $\Delta\theta_2$  specified in Table 7 apply.

**Table 7 — Values for  $\Delta\theta_2$**

Clamp length $\Sigma t^a$	$\Delta\theta_2$ min.
$\Sigma t < 2 d$	180°
$2 d \leq \Sigma t < 6 d$	210°
$6 d \leq \Sigma t \leq 10 d$	240°

<sup>a</sup>  $\Sigma t$  is the total thickness of the clamped parts including washers.

## 7.5 Individual values of the $k$ -factor ( $k_i$ ), mean value of the $k$ -factor ( $k_m$ ) and coefficient of variation of the $k$ -factor ( $V_k$ )

### 7.5.1 Individual values of the $k$ -factor ( $k_i$ ) for $k$ -class K1

For  $k$ -class K1, the  $k_i$  values shall be within the range of  $0,10 \leq k_i \leq 0,16$ .

### 7.5.2 Mean value of the $k$ -factor ( $k_m$ ) and coefficient of variation of the $k$ -factor ( $V_k$ ) for $k$ -class K2

The mean value ( $k_m$ ) of the  $k$ -factor shall be calculated as follows:

$$k_m = \frac{\sum_{i=1}^n k_i}{n}$$

with

$$k_i = \frac{M_i}{F_{p,C} \times d}$$

where

$M_i$  is the individual value of the applied torque;

$F_{p,C}$  is the required preload;

$d$  is the nominal bolt diameter.

The coefficient of variation of the  $k$ -factor ( $V_k$ ) shall be calculated as follows:

$$V_k = \frac{s_k}{k_m}$$

where

$$s_k \text{ is the standard deviation } \left( s_k = \sqrt{\frac{\sum (k_i - k_m)^2}{n - 1}} \right)$$

When  $k_m$  and  $V_k$  the following values apply:

$$0,10 \leq k_m \leq 0,23$$

$$V_k \leq 0,06$$

**Annex A**  
(normative)

**Clamp lengths and Grip lengths**

See Figure A.1 and Tables A.1 and A.2.

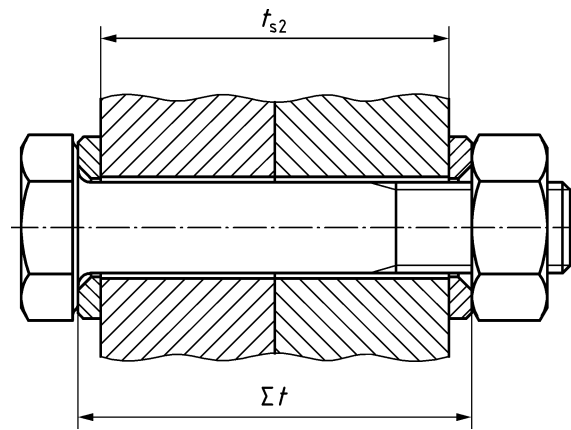

**Figure A.1 — Clamp length  $\Sigma t$  and Grip length  $t_{s2}$**

**Table A.1 — Clamp lengths  $\Sigma l$ <sup>a</sup>**

Dimensions in millimetres

Thread ( <i>d</i> )			M12		M16		M20		M22		M24		M27		M30		M36	
<i>l</i>			$\Sigma l_{\min}$ and $\Sigma l_{\max}$															
nom.	min.	max.	min.	max.	min.	max.	min.	max.	min.	max.	min.	max.	min.	max.	min.	max.	min.	max.
35	33,75	36,25	16	21														
40	38,75	41,25	21	26	17	22												
45	43,75	46,25	26	31	22	27	18	23										
50	48,75	51,25	31	36	27	32	23	28	22	27								
55	53,5	56,5	36	41	32	37	28	33	27	32								
60	58,5	61,5	41	46	37	42	33	38	32	37	29	34						
65	63,5	66,5	46	51	42	47	38	43	37	42	34	39						
70	68,5	71,5	51	56	47	52	43	48	42	47	39	44	36	41				
75	73,5	76,5	56	61	52	57	48	53	47	52	44	49	41	46	39	44		
80	78,5	81,5	61	66	57	62	53	58	52	57	49	54	46	51	44	49		
85	83,25	86,75	66	71	62	67	58	63	57	62	54	59	51	56	49	54	43	48
90	88,25	91,75	71	76	67	72	63	68	62	67	59	64	56	61	54	59	48	53
95	93,25	96,75	76	81	72	77	68	73	67	72	64	69	61	66	59	64	53	58
100	98,25	101,75			77	82	73	78	72	77	69	74	66	71	64	69	58	63
105	103,25	106,75			82	87	78	83	77	82	74	79	71	76	69	74	63	68
110	108,25	111,75			87	92	83	88	82	87	79	84	76	81	74	79	68	73
115	113,25	116,75			92	97	88	93	87	92	84	89	81	86	79	84	73	78
120	118,25	121,75			97	102	93	98	92	97	89	94	86	91	84	89	78	83
125	123	127			102	107	98	103	97	102	94	99	91	96	89	94	83	88
130	128	132			107	112	103	108	102	107	99	104	96	101	94	99	88	93
135	133	137					108	113	107	112	104	109	101	106	99	104	93	98
140	138	142					113	118	112	117	109	114	106	111	104	109	98	103
145	143	147					118	123	117	122	114	119	111	116	109	114	103	108
150	148	152					123	128	122	127	119	124	116	121	114	119	108	113
155	153	159					128	133	127	132	124	129	121	126	119	124	113	118
160	158	164							132	137	129	134	126	131	124	129	118	123
165	163	169							137	142	134	139	131	136	129	134	123	128
170	168	174									139	144	136	141	134	139	128	133
175	173	179									144	149	141	146	139	144	133	138
180	178	184									149	154	146	151	144	149	138	143
185	182,7	189,6									154	159	151	156	149	154	143	148
190	187,7	194,6									159	164	156	161	154	159	148	153
195	192,7	199,6									164	169	161	166	159	164	153	158
200	197,7	204,6											166	171	164	169	158	163

NOTE Preferred lengths are defined in terms of lengths  $\Sigma l_{\min}$  and  $\Sigma l_{\max}$ .

<sup>a</sup> For proper function of the preloaded bolted joint, the following condition for the clamp length  $\Sigma l$  shall be fulfilled:  
 $(l_{g,\max} + 2 P) < \Sigma l < (l_{\min} - P - m_{\max})$ , where  $P$  is the pitch of thread and  $m_{\max}$  is the maximum nut height according to Table 4.  
 The values of  $\Sigma l_{\min}$  and  $\Sigma l_{\max}$  specified in Table A.1 are within this range.  
 The  $\Sigma l_{\max}$  values are specified on the condition that the minimum bolt protrusion beyond the unloaded nut face shall be  $1 P$ .

**Table A.2 — Grip length  $t_{s2}$ <sup>a</sup>**

Dimensions in millimetres

Thread ( <i>d</i> )	M12		M16		M20		M22		M24		M27		M30		M36	
	$t_{s2,min}$ and $t_{s2,max}$															
<i>l</i> nom.	min.	max.	min.	max.	min.	max.	min.	max.	min.	max.	min.	max.	min.	max.	min.	max.
35	10	15														
40	15	20	9	14												
45	20	25	14	19	10	15										
50	25	30	19	24	15	20	14	19								
55	30	35	24	29	20	25	19	24								
60	35	40	29	34	25	30	24	29	21	26						
65	40	45	34	39	30	35	29	34	26	31						
70	45	50	39	44	35	40	34	39	31	36	26	31				
75	50	55	44	49	40	45	39	44	36	41	31	36	29	34		
80	55	60	49	54	45	50	44	49	41	46	36	41	34	39		
85	60	65	54	59	50	55	49	54	46	51	41	46	39	44	31	36
90	65	70	59	64	55	60	54	59	51	56	46	51	44	49	36	41
95	70	75	64	69	60	65	59	64	56	61	51	56	49	54	41	46
100			69	74	65	70	64	69	61	66	56	61	54	59	46	51
105			74	79	70	75	69	74	66	71	61	66	59	64	51	56
110			79	84	75	80	74	79	71	76	66	71	64	69	56	61
115			84	89	80	85	79	84	76	81	71	76	69	74	61	66
120			89	94	85	90	84	89	81	86	76	81	74	79	66	71
125			94	99	90	95	89	94	86	91	81	86	79	84	71	76
130			99	104	95	100	94	99	91	96	86	91	84	89	76	81
135					100	105	99	104	96	101	91	96	89	94	81	86
140					105	110	104	109	101	106	96	101	94	99	86	91
145					110	115	109	114	106	111	101	106	99	104	91	96
150					115	120	114	119	111	116	106	111	104	109	96	101
155					120	125	119	124	116	121	111	116	109	114	101	106
160							124	129	121	126	116	121	114	119	106	111
165							129	134	126	131	121	126	119	124	111	116
170									131	136	126	131	124	129	116	121
175									136	141	131	136	129	134	121	126
180									141	146	136	141	134	139	126	131
185									146	151	141	146	139	144	131	136
190									151	156	146	151	144	149	136	141
195									156	161	151	156	149	154	141	146
200											156	161	154	159	146	151

NOTE The popular lengths are defined in terms of lengths  $t_{s2,min}$  and  $t_{s2,max}$ .

<sup>a</sup> For proper function of the preloaded bolted joint, the following condition for the grip length  $t_{s2}$  shall be fulfilled:  
 $(l_{g,max} + 2P - 2h_{min}) < t_{s2} < (l_{min} - P - m_{max} - 2h_{max})$ , where  $P$  is the pitch of thread,  $m_{max}$  is the maximum nut height and  $h_{min}$  is the minimum washers thickness.  
 The values of  $t_{s2,min}$  and  $t_{s2,max}$  specified in Table A.2 are within this range.

## Bibliography

- [1] EN 1090-2, *Execution of steel structures and aluminium structures - Part 2: Technical requirements for steel structures*
- [2] EN 1993-1-8, *Eurocode 3: Design of steel structures - Part 1-8: Design of joints*
- [3] EN 14399-3, *High-strength structural bolting assemblies for preloading - Part 3: System HR - Hexagon bolt and nut assemblies*
- [4] EN 14399-6, *High-strength structural bolting assemblies for preloading - Part 6: Plain chamfered washers*
- [5] EN 14399-7, *High-strength structural bolting assemblies for preloading - Part 7: System HR - Countersunk head bolt and nut assemblies*
- [6] EN 14399-8, *High-strength structural bolting assemblies for preloading - Part 8: System HV - Hexagon fit bolt and nut assemblies*
- [7] EN 14399-9, *High-strength structural bolting assemblies for preloading - Part 9: System HR or HV - Direct tension indicators for bolt and nut assemblies*
- [8] EN 14399-10, *High-strength structural bolting assemblies for preloading - Part 10: System HRC - Bolt and nut assemblies with calibrated preload*
- [9] ISO 272, *Fasteners - Hexagon products - Widths across flats*

*This page deliberately left blank*

# British Standards Institution (BSI)

BSI is the national body responsible for preparing British Standards and other standards-related publications, information and services.

BSI is incorporated by Royal Charter. British Standards and other standardization products are published by BSI Standards Limited.

## About us

We bring together business, industry, government, consumers, innovators and others to shape their combined experience and expertise into standards-based solutions.

The knowledge embodied in our standards has been carefully assembled in a dependable format and refined through our open consultation process. Organizations of all sizes and across all sectors choose standards to help them achieve their goals.

## Information on standards

We can provide you with the knowledge that your organization needs to succeed. Find out more about British Standards by visiting our website at [bsigroup.com/standards](http://bsigroup.com/standards) or contacting our Customer Services team or Knowledge Centre.

## Buying standards

You can buy and download PDF versions of BSI publications, including British and adopted European and international standards, through our website at [bsigroup.com/shop](http://bsigroup.com/shop), where hard copies can also be purchased.

If you need international and foreign standards from other Standards Development Organizations, hard copies can be ordered from our Customer Services team.

## Subscriptions

Our range of subscription services are designed to make using standards easier for you. For further information on our subscription products go to [bsigroup.com/subscriptions](http://bsigroup.com/subscriptions).

With **British Standards Online (BSOL)** you'll have instant access to over 55,000 British and adopted European and international standards from your desktop. It's available 24/7 and is refreshed daily so you'll always be up to date.

You can keep in touch with standards developments and receive substantial discounts on the purchase price of standards, both in single copy and subscription format, by becoming a **BSI Subscribing Member**.

**PLUS** is an updating service exclusive to BSI Subscribing Members. You will automatically receive the latest hard copy of your standards when they're revised or replaced.

To find out more about becoming a BSI Subscribing Member and the benefits of membership, please visit [bsigroup.com/shop](http://bsigroup.com/shop).

With a **Multi-User Network Licence (MUNL)** you are able to host standards publications on your intranet. Licences can cover as few or as many users as you wish. With updates supplied as soon as they're available, you can be sure your documentation is current. For further information, email [bsmusales@bsigroup.com](mailto:bsmusales@bsigroup.com).

## BSI Group Headquarters

389 Chiswick High Road London W4 4AL UK

## Revisions

Our British Standards and other publications are updated by amendment or revision.

We continually improve the quality of our products and services to benefit your business. If you find an inaccuracy or ambiguity within a British Standard or other BSI publication please inform the Knowledge Centre.

## Copyright

All the data, software and documentation set out in all British Standards and other BSI publications are the property of and copyrighted by BSI, or some person or entity that owns copyright in the information used (such as the international standardization bodies) and has formally licensed such information to BSI for commercial publication and use. Except as permitted under the Copyright, Designs and Patents Act 1988 no extract may be reproduced, stored in a retrieval system or transmitted in any form or by any means – electronic, photocopying, recording or otherwise – without prior written permission from BSI. Details and advice can be obtained from the Copyright & Licensing Department.

## Useful Contacts:

### Customer Services

**Tel:** +44 845 086 9001

**Email (orders):** [orders@bsigroup.com](mailto:orders@bsigroup.com)

**Email (enquiries):** [cservices@bsigroup.com](mailto:cservices@bsigroup.com)

### Subscriptions

**Tel:** +44 845 086 9001

**Email:** [subscriptions@bsigroup.com](mailto:subscriptions@bsigroup.com)

### Knowledge Centre

**Tel:** +44 20 8996 7004

**Email:** [knowledgecentre@bsigroup.com](mailto:knowledgecentre@bsigroup.com)

### Copyright & Licensing

**Tel:** +44 20 8996 7070

**Email:** [copyright@bsigroup.com](mailto:copyright@bsigroup.com)



...making excellence a habit.™